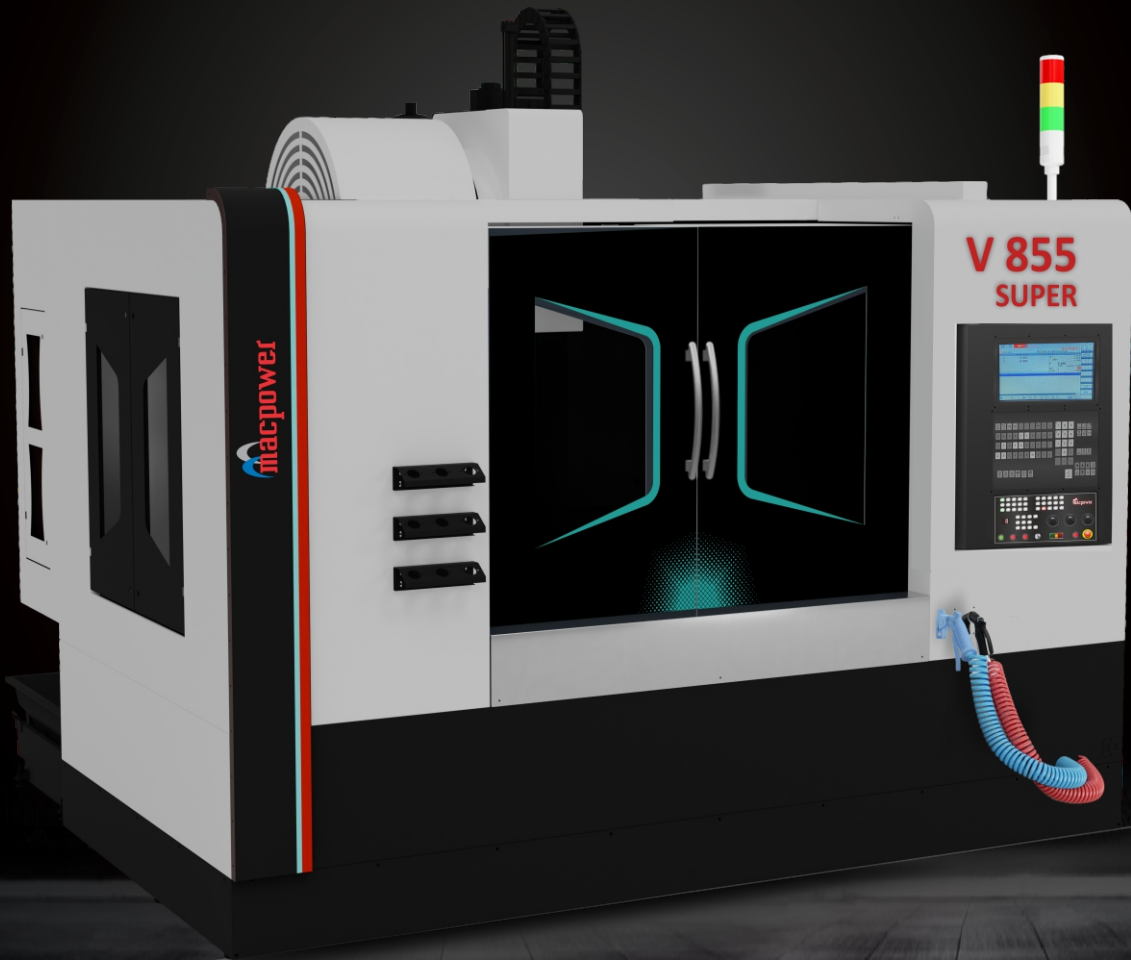


ALL **NEW** 5TH GENERATION

SERIES



VERTICAL MACHINING CENTER



VIBRANT SERIES

ONE NUMBER - MULTI SOLUTIONS

FOR SALES INQUIRIES & CUSTOMER CARE



96-1098-1098

WWW.MACPOWERCNC.COM



WHY MACPOWER ?

- Totally In-house Manufacturing Capability
- Choose from wide range of products
- Effective "Cost to Performance" solution provider
- Believing in partnership with customers and not as buyer and seller
- Efficient after sales service back up
- Availability of spares
- Emphasis on continuous R & D & Training
- Flexibility & Openness to manufacture customized machines
- Fast decision making process
- Macpower is a company with a modern outlook – giving you contemporary solutions through time-tested expertise.

COMPANY PROFILE

Macpower CNC Machines Limited (Macpower) welcomes to the world of machining excellence. More than one and half decades of experience and the vision towards creating a niche has transformed Macpower into India's fastest growing CNC Manufacturing Company. This meteoric growth is a result of Macpower's vision of par excellence to manufacture state of the art products, adopting the best in technology.

In 2003, Macpower Group started Macpower CNC Machines Limited, CNC Machines manufacturing unit in an area of around 4 acres and has grown to almost double thereafter with 2 units in operation at present situated at Metoda G. I. D.C., Rajkot (India). Macpower is registered to ISO 9001(Design), a universally accepted quality assurance designation and MSE-1 certification for highest financial strength and operational ability by CRISIL.

The modern headquarters contains a spacious State of the Art Machine Shop, Totally Equipped Assembly Shops, All Modern Measuring and Testing Equipments, Technologically Advanced Sheet Metal Unit and One of it's Kind Powder Coating Plant make Macpower Totally In-House Manufacturing Company.

Macpower is currently offering widest range of 9 different product categories namely Turning Center, Twin Spindle Turning Center, VMC, Twin Spindle VMC, TurnMill Center, HMC, VTL, DTC, Grinder with 27 versions and 60+ different models serving 27 industry segment world wide with 8000+ installations.

Sales & Service Team presence in 37 cities across the country with 107 qualified engineers and 9 business associates; establishment of multiple regional offices and technology centers across the country to have better connect with our valued customers.

INFRASTRUCTURE



MACHINE SHOP AREA



ASSEMBLY AREA



POWDER COATING AREA



SHEET METAL AREA

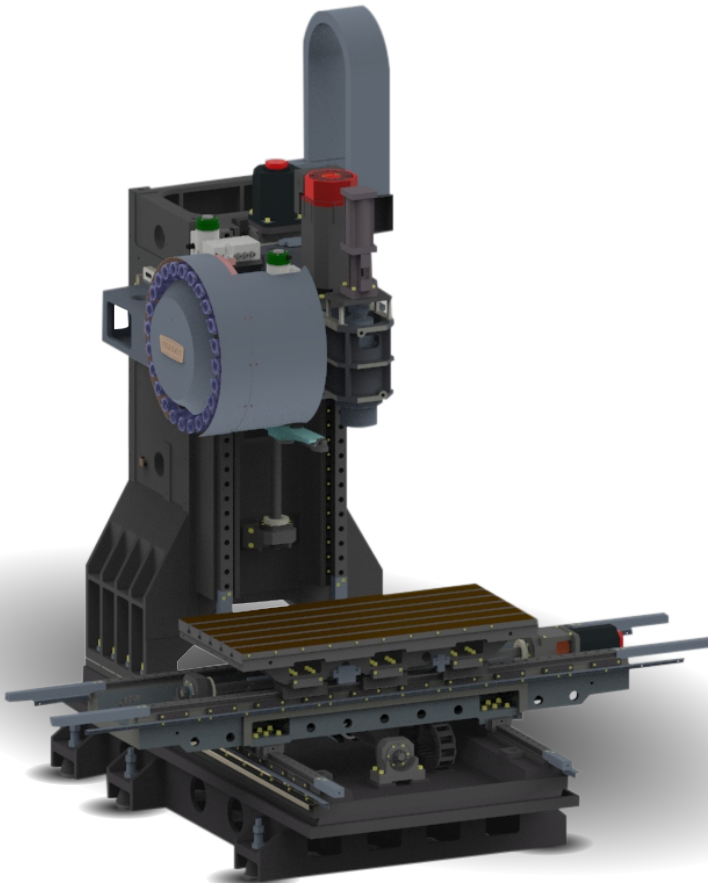


SPINDLE ASSEMBLY AREA



RESEARCH AND DEVELOPMENT

RIGID STRUCTURE



Sturdiness of the foundation determined the soundness of the structure. The major construction parts are based on FG260 grade cast iron, to ensure optimum harmonic stability and maximum damping during cutting. Base and column are reinforced with heavy ribs for stability and least distortion. The uniform dense, fine graded casting distributed stress and heat throughout the machine structure.

HIGH CAPACITY **ACCURATE SPINDLE**



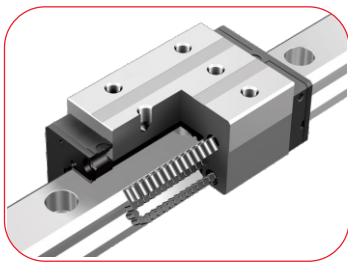
The precision cartridge spindle unit having three super precise angular contact bearings at front and two at rear end, this combination ensures higher stiffness. Bearings are perfectly aligned and grease packed for long life. Spindle is indirectly driven by high speed AC spindle motor with reduced pulley ratio, to achieve high spindle torque and optimal performance of machine.

DOUBLE-ANCHORED **BALL SCREWS**



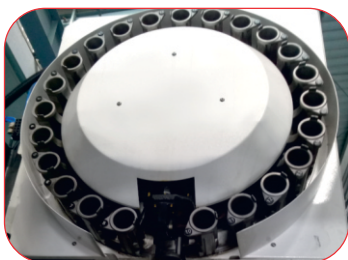
Ball Screws are directed by direct coupled AC servo motor with flexible coupling. This greatly improves positioning accuracy, and provides more accurate threading and contouring. Ball Screws are anchored at both ends and inspected for parallelism with axis guide. Pre-loaded ball nuts eliminate backlash.

HEAVY DUTY ROLLER LM **GUIDEWAYS**



All axes are furnished with precise and heavy load capacity re-circulating roller guide ways enabling high acceleration-de acceleration and hence better rigidity.

RELIABLE **ATC**



Twin arm type side mounted ATC driven by screw and cam speed up tool changing time with random access and resulted in reduce cycle time and higher productivity. Each subsystem is tested for innumerable cycle at every stage to enhance reliability.

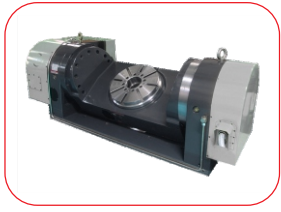
ADVANCE INSPECTION **TECHNOLOGY**



Laser Calibration is carried out to insure the linear accuracy, providing accurate compensation for pitch and backlash. The machine facilities the attainment of positional accuracy up to 0.01 mm / 300 mm and repeatability accuracy up to 0.007 mm.

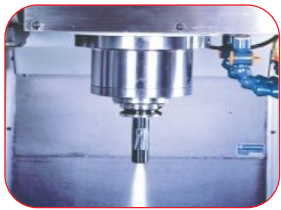
PRODUCTIVITY ENHANCEMENT OPTIONS

4TH & 5TH AXIS CAPABILITY



For maximum application and cutting flexibility, usage of 4th Axis or 5th Axis rotary table with high resolution feedback system can be opted. These rotary tables can be programmed through the control system, that can be used to increase productivity by multiple side workpiece in single setting

COOLANT THROUGH SPINDLE (CTS)



This option provides high pressure filtered coolant directly to the cutting edge minimizing heat distractions, ensuring maximum productivity with today's high performance tooling. High recommended for jobs demanding deep boring and tapping.

GEAR BOX



For application requiring high cutting for harder material or high cutting speed for soft materials, 2-speed gearbox need to be opted. These gearbox provide higher cutting torque at lower RPM with auto shifting mechanism keeping power constant. Such gearbox get directly coupled to main spindle motor giving production flexibility without disturbing precision.

FLUSH COOLANT SYSTEM

Efficient chip remove is one of the important factor for better productivity with un-interrupted machining operations can be efficiently enhanced by selections of flush coolant system, high pressure coolant splash via flexible nozzles can be targeted to area of maximum chip accumulation. such a system enhance reduction in machining down time to operate and hence positively effecting productivity.

CHIP CONVEYOR



Machine can be mounted with chip conveyor option for efficient Swarf removal for entire series. such type of arrangements is very much useful for applications requiring continues machining hours having much metal removal. with help of downtime can be reduce drastically.

PROBES



A wide choice of spindle and surface-sensing probes as tool & job probes with infrared / radio laser transmission technology are available for increased spindle utilization, work piece setup and work piece measurement.

VIBRANT 400

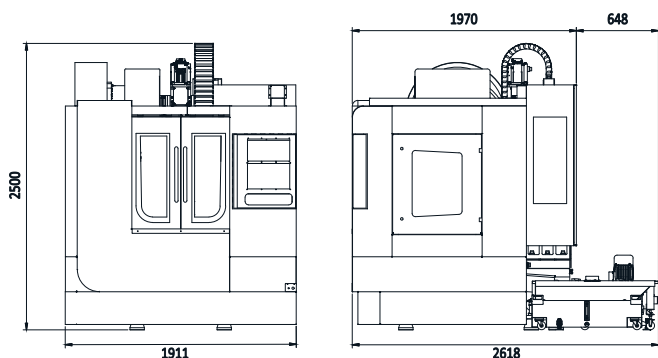


TABLE SIZE	MM	300x600
AXIS STROKE (X / Y / Z)	MM	410 / 300 / 300
RAPID FEED RATES X/Y/Z AXIS	M/MIN	30 / 30 / 30
LOAD CAPACITY	KG	250
SPINDLE	-	BT 40
SPINDLE POWER (FANUC)	KW	5.5 / 7.5
WEIGHT (APPROX)	KG	3150
DIMENSIONS (APPROX) (WXDXH)	MM	1911x2618x2500

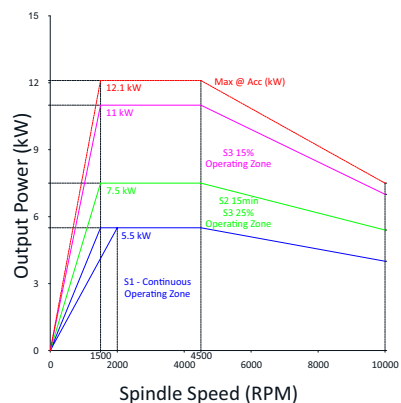
COMPONENTS



MACHINE DIMENSIONS



MACHINING RANGE & POWER DIAGRAM



VIBRANT 500

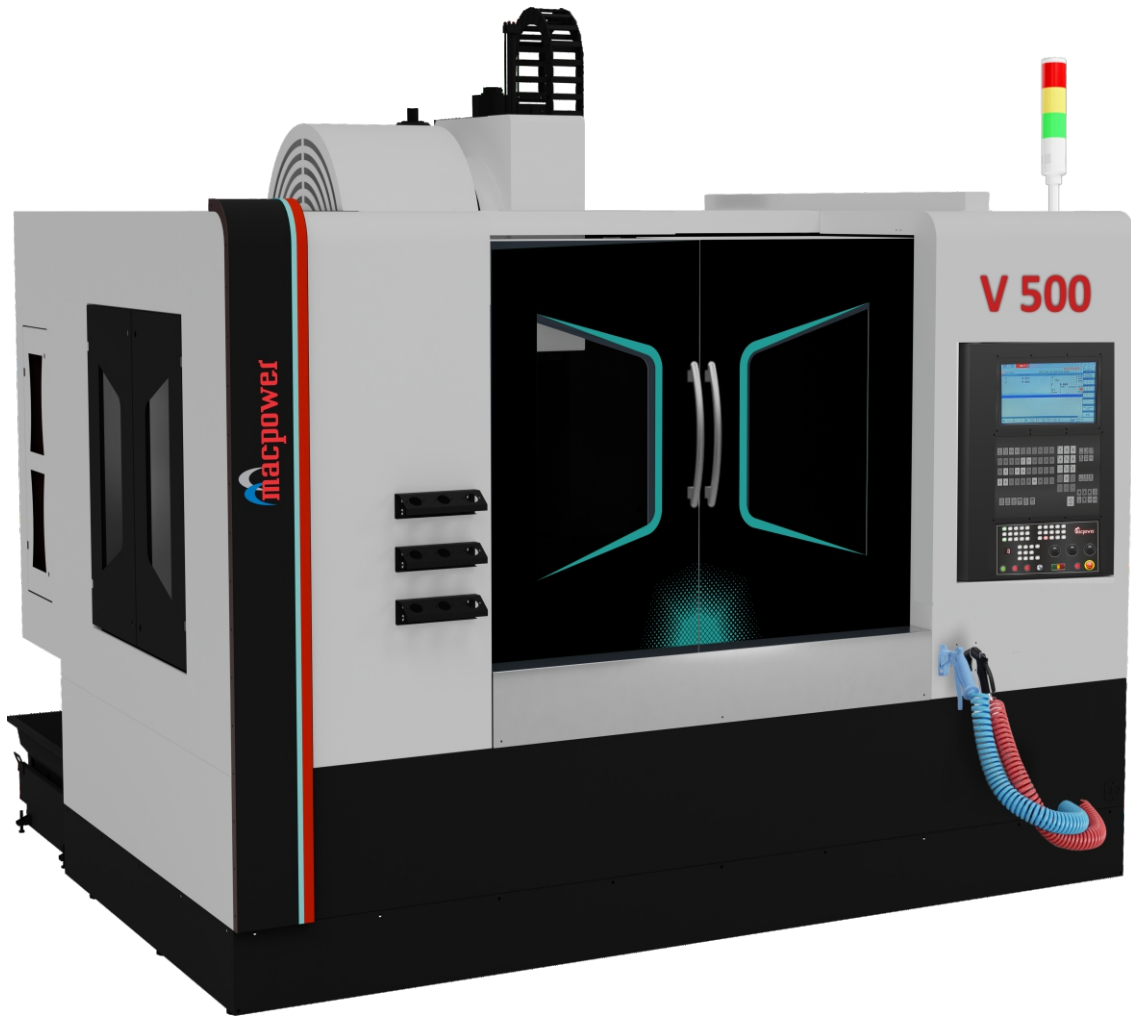
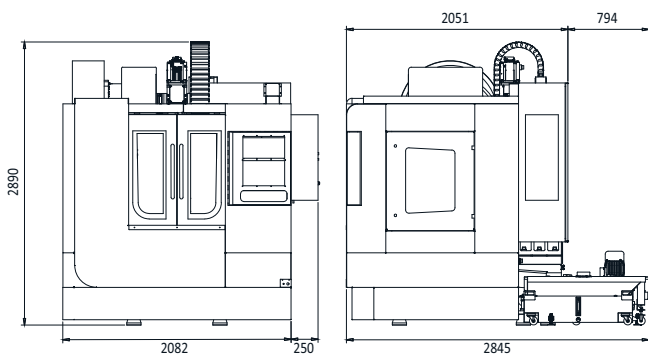


TABLE SIZE (CLAMPING AREA)	MM	450x650
AXIS STROKE (X / Y / Z)	MM	525 / 500 / 500
RAPID FEED RATES X/Y/Z AXIS	M/MIN	30 / 30 / 30
LOAD CAPACITY	KG	500
SPINDLE	-	BT 40
RATED POWER(FANUC)	KW	5.5 / 7.5
WEIGHT (APPROX)	KG	4060
DIMENSIONS (APPROX) (WXDXH)	MM	2332x2845x2890

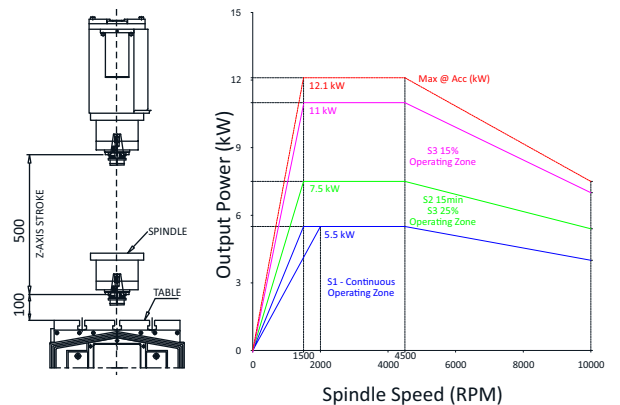
COMPONENTS



MACHINE DIMENSIONS



MACHINING RANGE & POWER DIAGRAM



VIBRANT 600

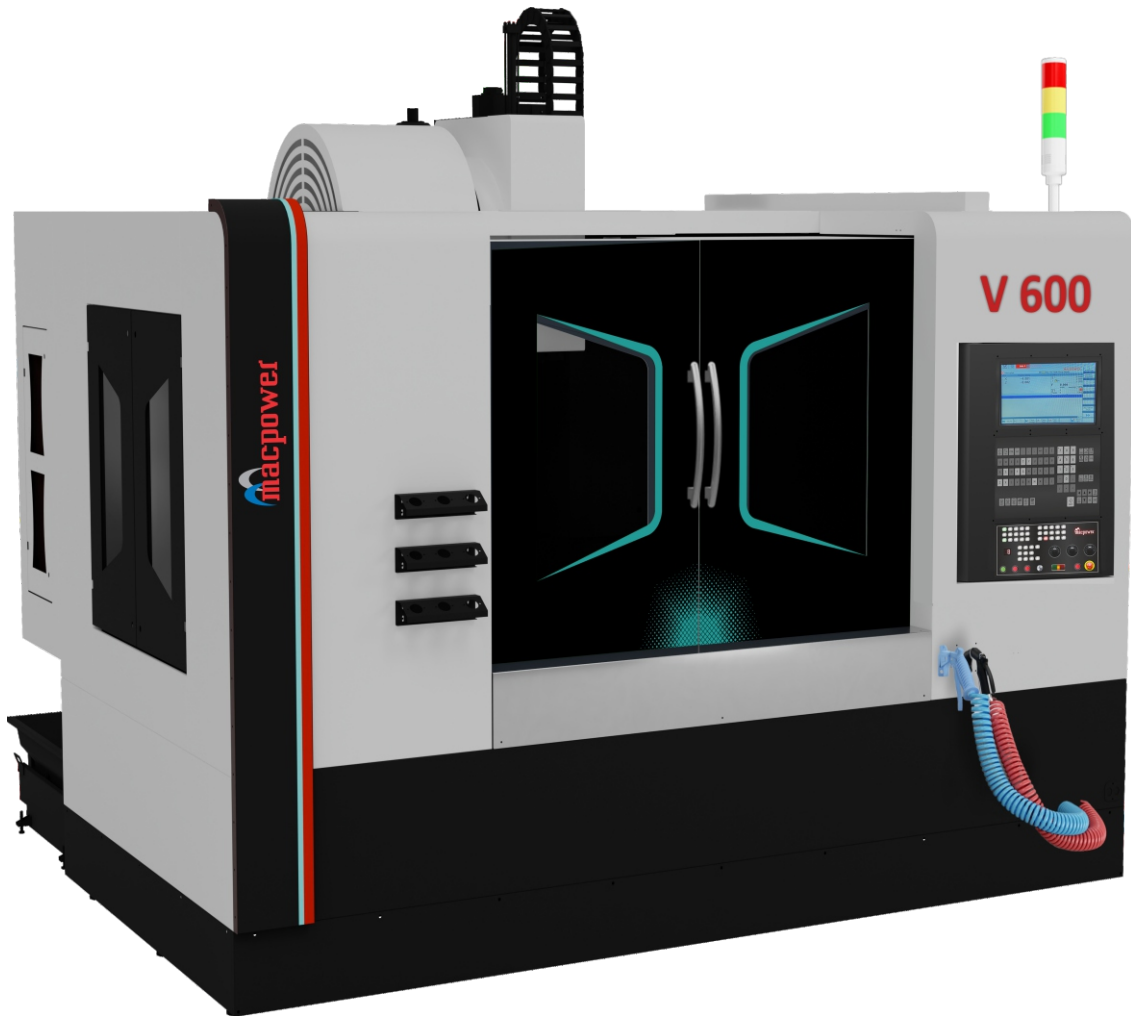
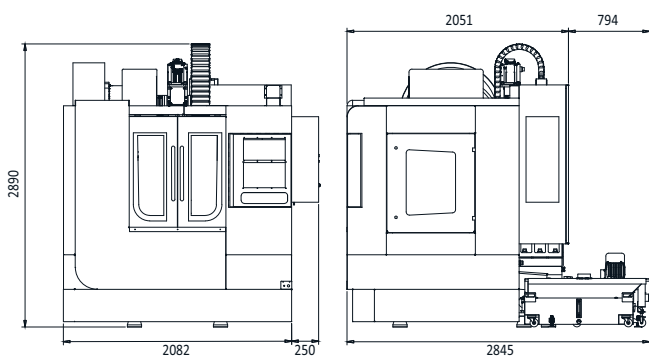


TABLE SIZE (CLAMPING AREA)	MM	500x800
AXIS STROKE (X / Y / Z)	MM	600 / 500 / 500
RAPID FEED RATES X/Y/Z AXIS	M/MIN	30 / 30 / 30
LOAD CAPACITY	KG	500
SPINDLE	-	BT 40
RATED POWER(FANUC)	KW	5.5 / 7.5
WEIGHT (APPROX)	KG	4360
DIMENSIONS (APPROX) (WXDXH)	MM	2332x2845x2890

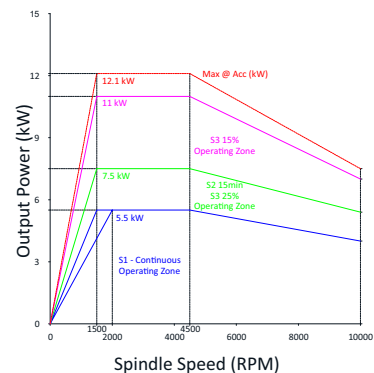
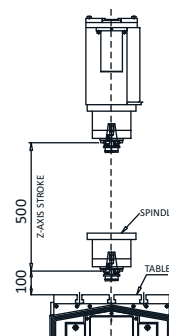
COMPONENTS



MACHINE DIMENSIONS



MACHINING RANGE & POWER DIAGRAM



VIBRANT 700

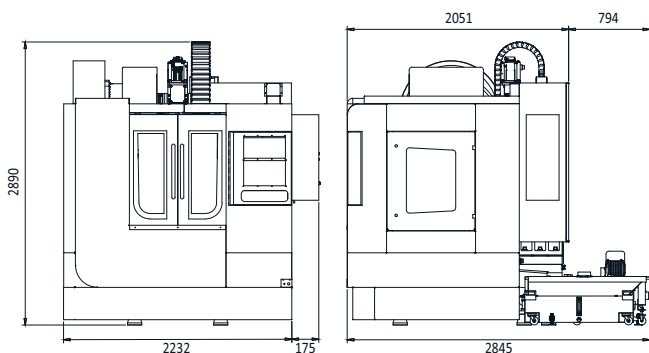


TABLE SIZE (CLAMPING AREA)	MM	500x900
AXIS STROKE (X / Y / Z)	MM	700 / 500 / 500
RAPID FEED RATES X/Y/Z AXIS	M/MIN	30 / 30 / 30
LOAD CAPACITY	KG	550
SPINDLE	-	BT 40
RATED POWER(FANUC)	KW	5.5 / 7.5
WEIGHT (APPROX)	KG	4400
DIMENSIONS (APPROX) (WXDXH)	MM	2407x2845x2890

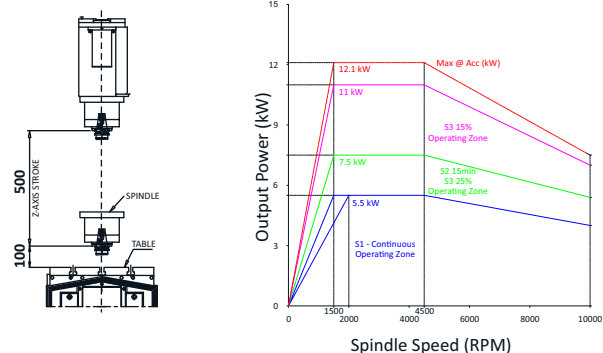
COMPONENTS



MACHINE DIMENSIONS



MACHINING RANGE & POWER DIAGRAM

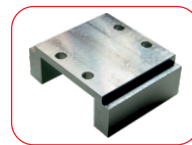


VIBRANT 800

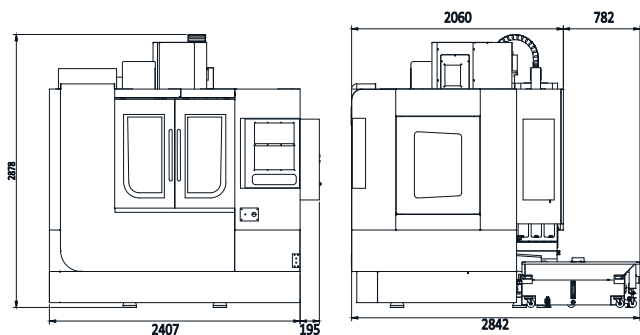


TABLE SIZE (CLAMPING AREA)	MM	500x1000
AXIS STROKE (X / Y / Z)	MM	800 / 550 / 550
RAPID FEED RATES X/Y/Z AXIS	M/MIN	30 / 30 / 30
LOAD CAPACITY	KG	600
SPINDLE	-	BT 40
RATED POWER(FANUC)	KW	7.5 / 11
WEIGHT (APPROX)	KG	4800
DIMENSIONS (APPROX) (WXDXH)	MM	2602x2842x2878

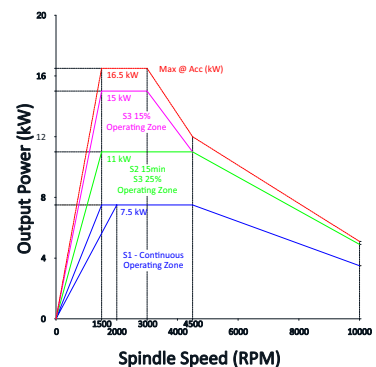
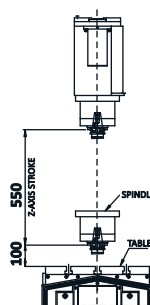
COMPONENTS



MACHINE DIMENSIONS



MACHINING RANGE & POWER DIAGRAM

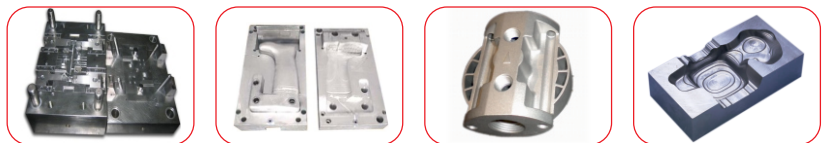


V 855 SUPER

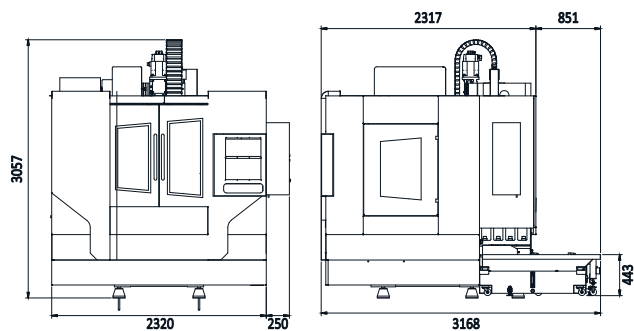


TABLE SIZE (CLAMPING AREA)	MM	500x1050
AXIS STROKE (X / Y / Z)	MM	850 / 510 / 510
RAPID FEED RATES X/Y/Z AXIS	M/MIN	36 / 36 / 36
LOAD CAPACITY	KG	800
SPINDLE	-	BT 40
RATED POWER(FANUC)	KW	7.5 / 11
WEIGHT (APPROX)	KG	5500
DIMENSIONS (APPROX) (WXDXH)	MM	2570x3168x3057 (BT-40)

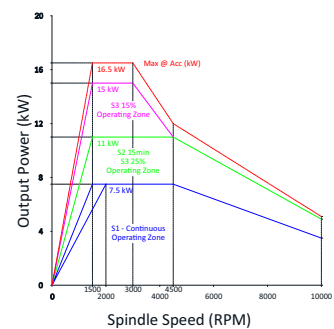
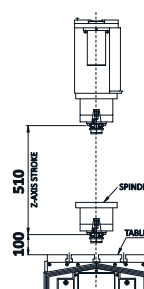
COMPONENTS



MACHINE DIMENSIONS



MACHINING RANGE & POWER DIAGRAM

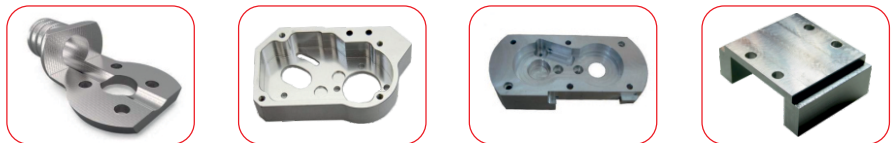


VIBRANT 900

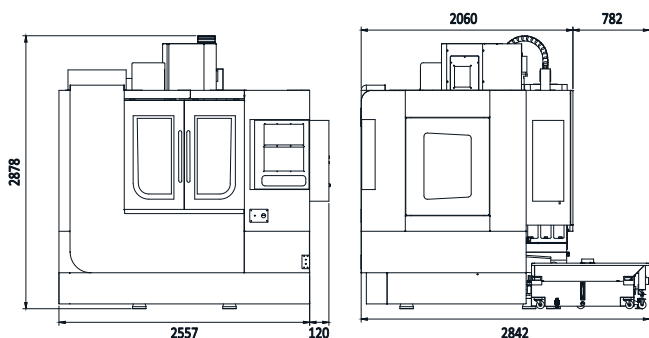


TABLE SIZE (CLAMPING AREA)	MM	500x1100
AXIS STROKE (X / Y / Z)	MM	900 / 550 / 550
RAPID FEED RATES X/Y/Z AXIS	M/MIN	30 / 30 / 30
LOAD CAPACITY	KG	900
SPINDLE	-	BT 40
RATED POWER(FANUC)	KW	7.5 / 11
WEIGHT (APPROX)	KG	5040
DIMENSIONS (APPROX) (WXDXH)	MM	2677x2842x2878

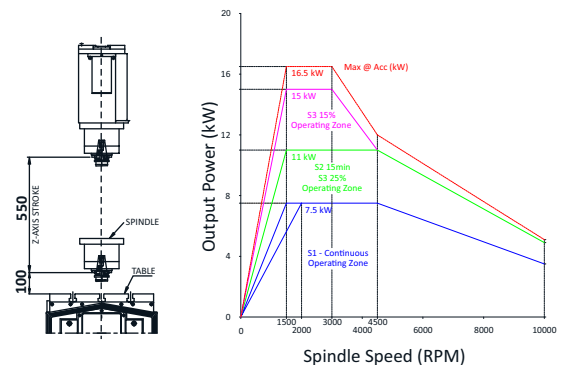
COMPONENTS



MACHINE DIMENSIONS



MACHINING RANGE & POWER DIAGRAM

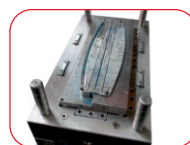
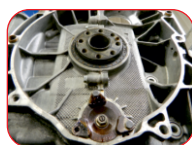


VIBRANT 1055

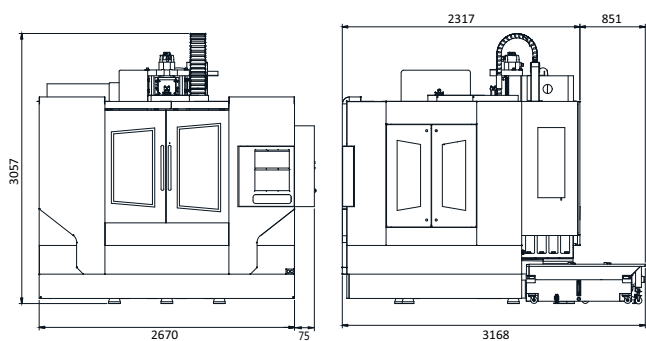


TABLE SIZE (CLAMPING AREA)	MM	500 x 1200
AXIS STROKE (X / Y / Z)	MM	1050 / 510 / 510
RAPID FEED RATES X/Y/Z AXIS	M/MIN	30 / 30 / 30
LOAD CAPACITY	KG	1000
SPINDLE	-	BT-40 / BT-50
RATED POWER(FANUC)	KW	11 / 15
WEIGHT (APPROX)	KG	6200
DIMENSIONS (APPROX) (WXDXH)	MM	2745x3168x3057 (BT-40) 2745x3168x3142 (BT-50)

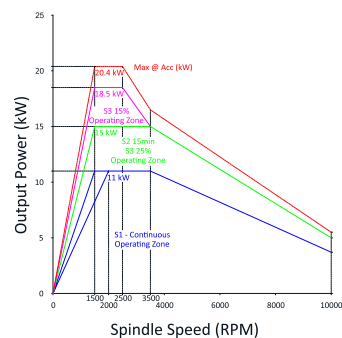
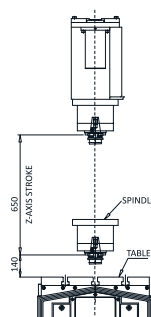
COMPONENTS



MACHINE DIMENSIONS



MACHINING RANGE & POWER DIAGRAM

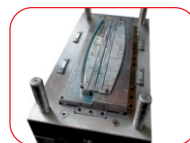


VIBRANT 1066

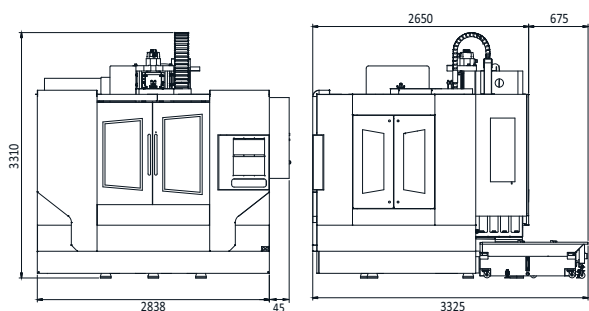


TABLE SIZE (CLAMPING AREA)	MM	600 x 1120
AXIS STROKE (X / Y / Z)	MM	1020 / 610 / 610
RAPID FEED RATES X/Y/Z AXIS	M/MIN	30 / 30 / 24
LOAD CAPACITY	KG	1200
SPINDLE	-	BT-40 / BT-50
RATED POWER(FANUC)	KW	11 / 15
WEIGHT (APPROX)	KG	-
DIMENSIONS (APPROX) (WXDXH)	MM	2883x3325x3310 (BT-40) 3554x3357x3685 (BT-50)

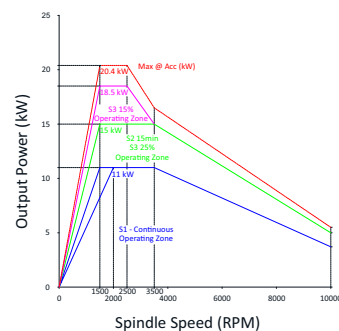
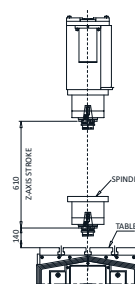
COMPONENTS



MACHINE DIMENSIONS



MACHINING RANGE & POWER DIAGRAM

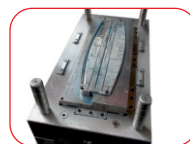


VIBRANT 1166

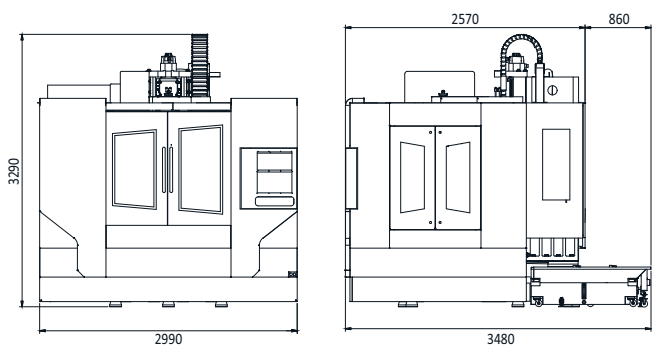


TABLE SIZE (CLAMPING AREA)	MM	600 x 1300
AXIS STROKE (X / Y / Z)	MM	1100 / 650 / 650
RAPID FEED RATES X/Y/Z AXIS	M/MIN	30 / 30 / 30
LOAD CAPACITY	KG	1100
SPINDLE	-	BT-40 / BT-50
RATED POWER(FANUC)	KW	11 / 15
WEIGHT (APPROX)	KG	7170 / 7860
DIMENSIONS (APPROX) (WXDXH)	MM	2990x3480x3290 (BT-40) 2990x3480x3375 (BT-50)

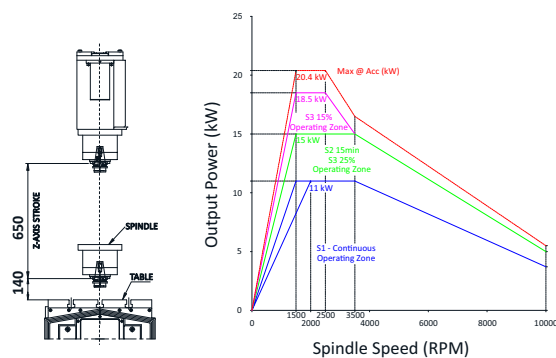
COMPONENTS



MACHINE DIMENSIONS



MACHINING RANGE & POWER DIAGRAM



VIBRANT 1366

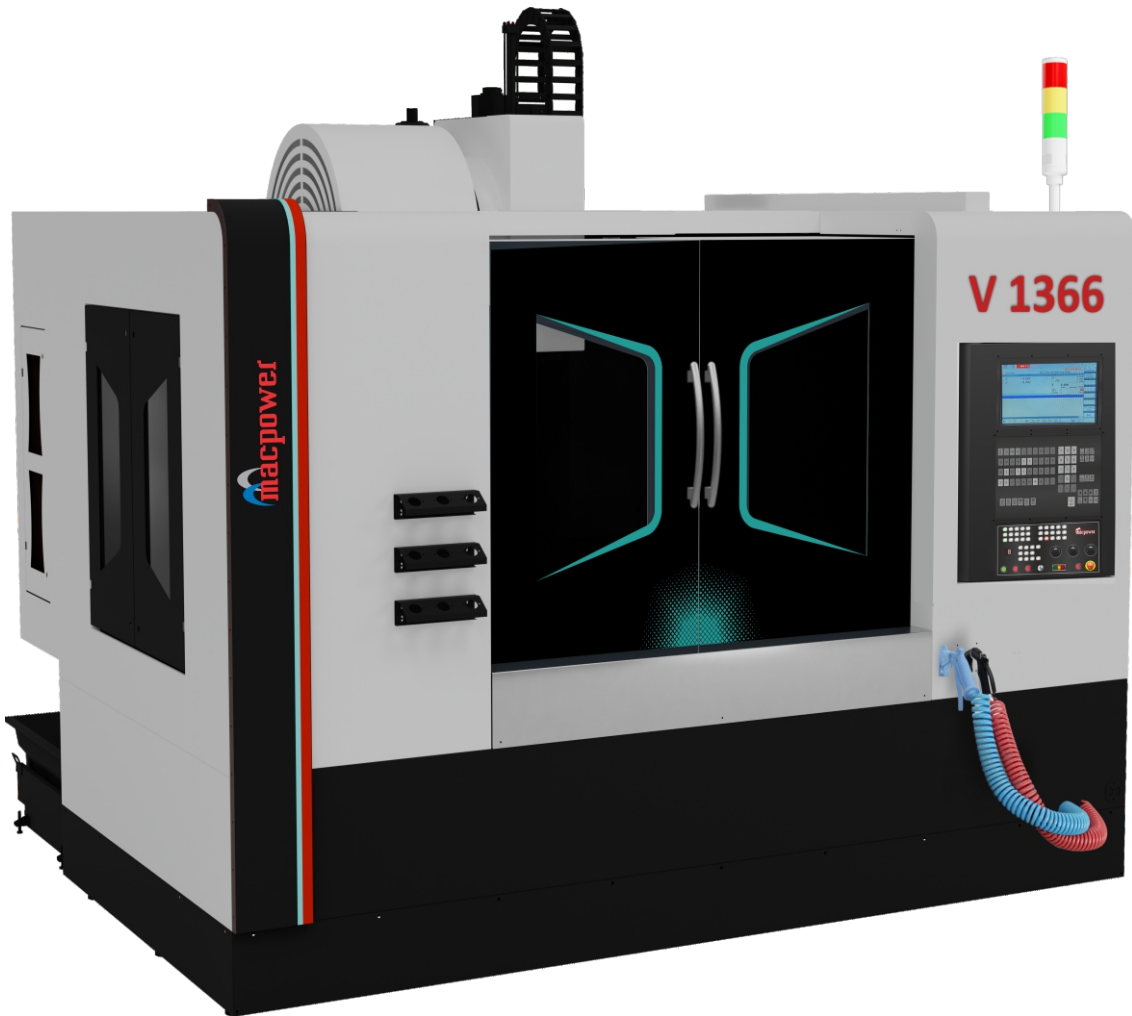
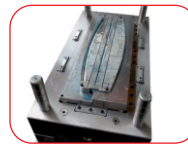
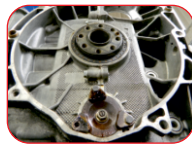
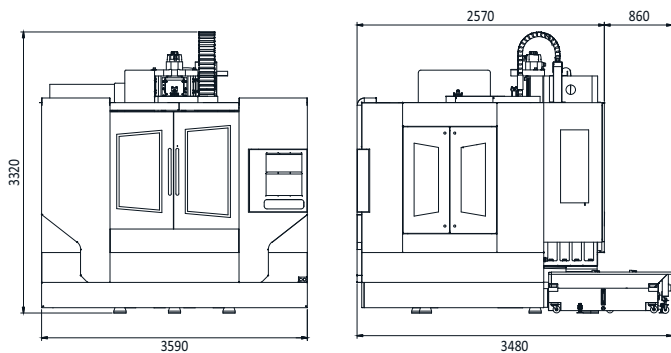


TABLE SIZE (CLAMPING AREA)	MM	650 x 1450
AXIS STROKE (X / Y / Z)	MM	1310 / 650 / 650
RAPID FEED RATES X/Y/Z AXIS	M/MIN	30 / 30 / 30
LOAD CAPACITY	KG	1300
SPINDLE	-	BT-40 / BT-50
RATED POWER(FANUC)	KW	11 / 15
WEIGHT (APPROX)	KG	7405 / 8055
DIMENSIONS (APPROX) (WXDXH)	MM	3590x3480x3320 (BT-40) 3590x3480x3405 (BT-50)

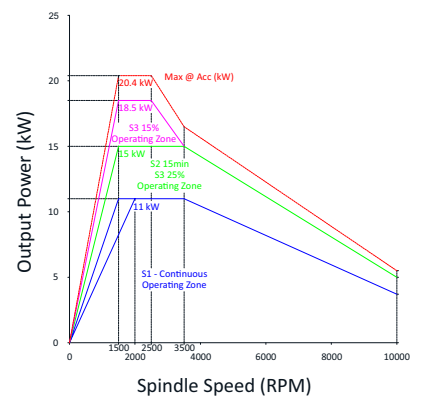
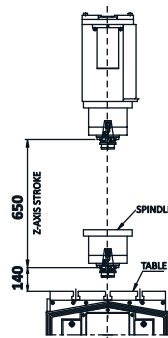
COMPONENTS



MACHINE DIMENSIONS



MACHINING RANGE & POWER DIAGRAM



ACCESSORIES

STANDARD

- ROLLER GUIDEWAYS
- 24 TOOL ATC
- WORK LIGHT
- HAND WHEEL
- LEVELING PAD
- RING COOLANT
- PATROL LIGHT
- AIR GUN
- CENTRALIZED LUBRICATION SYSTEM
- PULL STUD
- DRY AIR CUTTING

OPTIONAL

- COOLANT GUN
- AUTO DOOR
- CHIP CONVEYOR
- GLASS SCALE
- VOLTAGE STABILIZER
- FLUSH COOLANT
- COOLANT THROUGH SPINDLE
- 30 TOOL ATC
- ROTARY TABLE
- ROTARY TILTING TABLE
- GEAR BOX
- HIGHER RPM SPINDLES
- SPINDLE CHILLER
- INDEXER
- TOOL PROBE
- WORK PROBE
- TOOLED UP SOLUTIONS
- VERTICAL AXIS PULL UP DURING POWER FAILURE

VIBRANT – SERIES MACHINE CONFIGURATIONS

DESCRIPTION	UNIT	VIBRANT 400	VIBRANT 500
CAPACITY			
X AXIS TRAVEL	MM	410	525
Y AXIS TRAVEL	MM	300	500
Z AXIS TRAVEL	MM	300	500
RAPID FEED RATES X/Y/Z AXIS	M/MIN	30/30/30	30/30/30
DISTANCE FROM TABLE TO SPINDLE FACE	MM	100-400	100-600
TABLE			
TABLE SIZE (CLAMPING AREA)	MM	300x600	450x650
NO./WIDTH/CD OF T-SLOTS	MM	2/14/100	3/18/125
MAX SAFE LOAD ON TABLE	KG	250	500
MAIN SPINDLE			
TAPER	-	BT40	BT40
SPEED	RPM	80-8000	80-8000
CUTTING FEED RATE	MM/MIN.	1-10000	1-10000
RATED POWER (FANUC)	KW	5.5 / 7.5	5.5 / 7.5
AUTO TOOL CHANGER			
TYPE	-	TWIN ARM	TWIN ARM
NO. OF TOOLS	-	20	24
TOOL SELECTION	-	RANDOM	RANDOM
MAX. TOOL DIA. (POCKET FULL/EMPTY)	MM	80/150	80/150
TOOL LENGTH	MM	300	300
TOOL WEIGHT	KG	7	7
ACCURACY (AS PER JIS)			
POSITIONING	MM	0.01	0.01
REPEATABILITY	MM	0.007	0.007
INSTALLATION DATA			
PNEUMATIC SUPPLY	BAR	6	6
MACHINE WEIGHT (APPROX)	KG	3150	4060
TOTAL CONNECTED LOAD	KVA	16	16
POWER SUPPLY	-	"AC 440 V, 50HZ, 3 PH."	"AC 440 V, 50HZ, 3 PH."
MACHINE DIMENSIONS (WXDXH) (APPROX)	MM	1911 x 2618 x 2500	2332 x 2845 x 2890
SYSTEM			
FANUC	-	OI MF PLUS (ADV MILL)	OI MF PLUS (ADV MILL)
SIEMENS	-	828D	828D
MITSUBISHI	-	M80 V	M80 V

VIBRANT – SERIES MACHINE CONFIGURATIONS

DESCRIPTION	UNIT	VIBRANT 600	VIBRANT 700
CAPACITY			
X AXIS TRAVEL	MM	600	700
Y AXIS TRAVEL	MM	500	500
Z AXIS TRAVEL	MM	500	500
RAPID FEED RATES X/Y/Z AXIS	M/MIN	30/30/30	30/30/30
DISTANCE FROM TABLE TO SPINDLE FACE	MM	100-600	100-600
TABLE			
TABLE SIZE (CLAMPING AREA)	MM	500X800	500X900
NO./WIDTH/CD OF T-SLOTS	MM	4/18/100	4/18/100
MAX SAFE LOAD ON TABLE	KG	500	550
MAIN SPINDLE			
TAPER	-	BT40	BT40
SPEED	RPM	80-8000	80-8000
CUTTING FEED RATE	MM/MIN.	1-10000	1-10000
RATED POWER (FANUC)	KW	5.5 / 7.5	5.5 / 7.5
AUTO TOOL CHANGER			
TYPE	-	TWIN ARM	TWIN ARM
NO. OF TOOLS	-	24	24
TOOL SELECTION	-	RANDOM	RANDOM
MAX. TOOL DIA. (POCKET FULL/EMPTY)	MM	80/150	80/150
TOOL LENGTH	MM	300	300
TOOL WEIGHT	KG	7	7
ACCURACY (AS PER JIS)			
POSITIONING	MM	0.01	0.01
REPEATABILITY	MM	0.007	0.007
INSTALLATION DATA			
PNEUAMTIC SUPPLY	BAR	6	6
MACHINE WEIGHT (APPROX)	KG	4360	4400
TOTAL CONNECTED LOAD	KVA	16	16
POWER SUPPLY	-	"AC 440 V, 50HZ, 3 PH."	"AC 440 V, 50HZ, 3 PH."
MACHINE DIMENSIONS (WXDXH) (APPROX)	MM	2332 x 2845 x 2890	2407 x 2845 x 2890
SYSTEM			
FANUC	-	OI MF PLUS (ADV MILL)	OI MF PLUS (ADV MILL)
SIEMENS	-	828D	828D
MITSUBISHI	-	M80 V	M80 V

VIBRANT – SERIES MACHINE CONFIGURATIONS

DESCRIPTION	UNIT	VIBRANT 800	V 855 SUPER
CAPACITY			
X AXIS TRAVEL	MM	800	850
Y AXIS TRAVEL	MM	550	510
Z AXIS TRAVEL	MM	550	510
RAPID FEED RATES X/Y/Z AXIS	M/MIN	30/30/30	36/36/36
DISTANCE FROM TABLE TO SPINDLE FACE	MM	100-650	100-610
TABLE			
TABLE SIZE (CLAMPING AREA)	MM	500X1000	500X1050
NO./WIDTH/CD OF T-SLOTS	MM	4/18/100	4/18/100
MAX SAFE LOAD ON TABLE	KG	600	800
MAIN SPINDLE			
TAPER	-	BT40	BT40
SPEED	RPM	80-8000	80-8000
CUTTING FEED RATE	MM/MIN.	1-10000	1-10000
RATED POWER (FANUC)	KW	7.5 / 11	7.5 / 11
AUTO TOOL CHANGER			
TYPE	-	TWIN ARM	TWIN ARM
NO. OF TOOLS	-	24	24
TOOL SELECTION	-	RANDOM	RANDOM
MAX. TOOL DIA. (POCKET FULL/EMPTY)	MM	80/150	80/150
TOOL LENGTH	MM	300	300
TOOL WEIGHT	KG	7	7
ACCURACY (AS PER JIS)			
POSITIONING	MM	0.01	0.01
REPEATABILITY	MM	0.007	0.007
INSTALLATION DATA			
PNEUAMTIC SUPPLY	BAR	6	6
MACHINE WEIGHT (APPROX)	KG	4800	5500
TOTAL CONNECTED LOAD	KVA	19	19
POWER SUPPLY	-	"AC 440 V, 50HZ, 3 PH."	"AC 440 V, 50HZ, 3 PH."
MACHINE DIMENSIONS (WXDXH) (APPROX)	MM	2602 x 2842 x 2878	2570 x 3168 x 3057
SYSTEM			
FANUC	-	OI MF PLUS (ADV MILL)	OI MF PLUS (ADV MILL)
SIEMENS	-	828D	828D
MITSUBISHI	-	M80 V	M80 V

VIBRANT – SERIES MACHINE CONFIGURATIONS

DESCRIPTION	UNIT	VIBRANT 900	VIBRANT 1055
CAPACITY			
X AXIS TRAVEL	MM	900	1050
Y AXIS TRAVEL	MM	550	510
Z AXIS TRAVEL	MM	550	510
RAPID FEED RATES X/Y/Z AXIS	M/MIN	30/30/30	30/30/30
DISTANCE FROM TABLE TO SPINDLE FACE	MM	100–650	100–610
TABLE			
TABLE SIZE (CLAMPING AREA)	MM	500X1100	500x1200
NO./WIDTH/CD OF T-SLOTS	MM	4/18/100	4/18/100
MAX SAFE LOAD ON TABLE	KG	900	1000
MAIN SPINDLE			
TAPER	-	BT40	BT 40 / BT 50
SPEED	RPM	80–8000	80–8000
CUTTING FEED RATE	MM/MIN.	1-10000	1-10000
RATED POWER (FANUC)	KW	7.5 / 11	11 / 15
AUTO TOOL CHANGER			
TYPE	-	TWIN ARM	TWIN ARM
NO. OF TOOLS	-	24	24
TOOL SELECTION	-	RANDOM	RANDOM
MAX. TOOL DIA. (POCKET FULL/EMPTY)	MM	80/150	80/150
TOOL LENGTH	MM	300	300
TOOL WEIGHT	KG	7	7
ACCURACY (AS PER JIS)			
POSITIONING	MM	0.01	0.01
REPEATABILITY	MM	0.007	0.007
INSTALLATION DATA			
PNEUMATIC SUPPLY	BAR	6	6
MACHINE WEIGHT (APPROX)	KG	5040	6200
TOTAL CONNECTED LOAD	KVA	19	25
POWER SUPPLY	-	"AC 440 V, 50HZ, 3 PH."	AC 440 V, 50HZ, 3PH.
MACHINE DIMENSIONS (WXDXH) (APPROX)	MM	2677 x 2842 x 2878	2745x3168x3057
SYSTEM			
FANUC	-	O1 MF PLUS (ADV MILL)	O1 MF PLUS (ADV MILL)
SIEMENS	-	828D	828D
MITSUBISHI	-	M80 V	M80 V

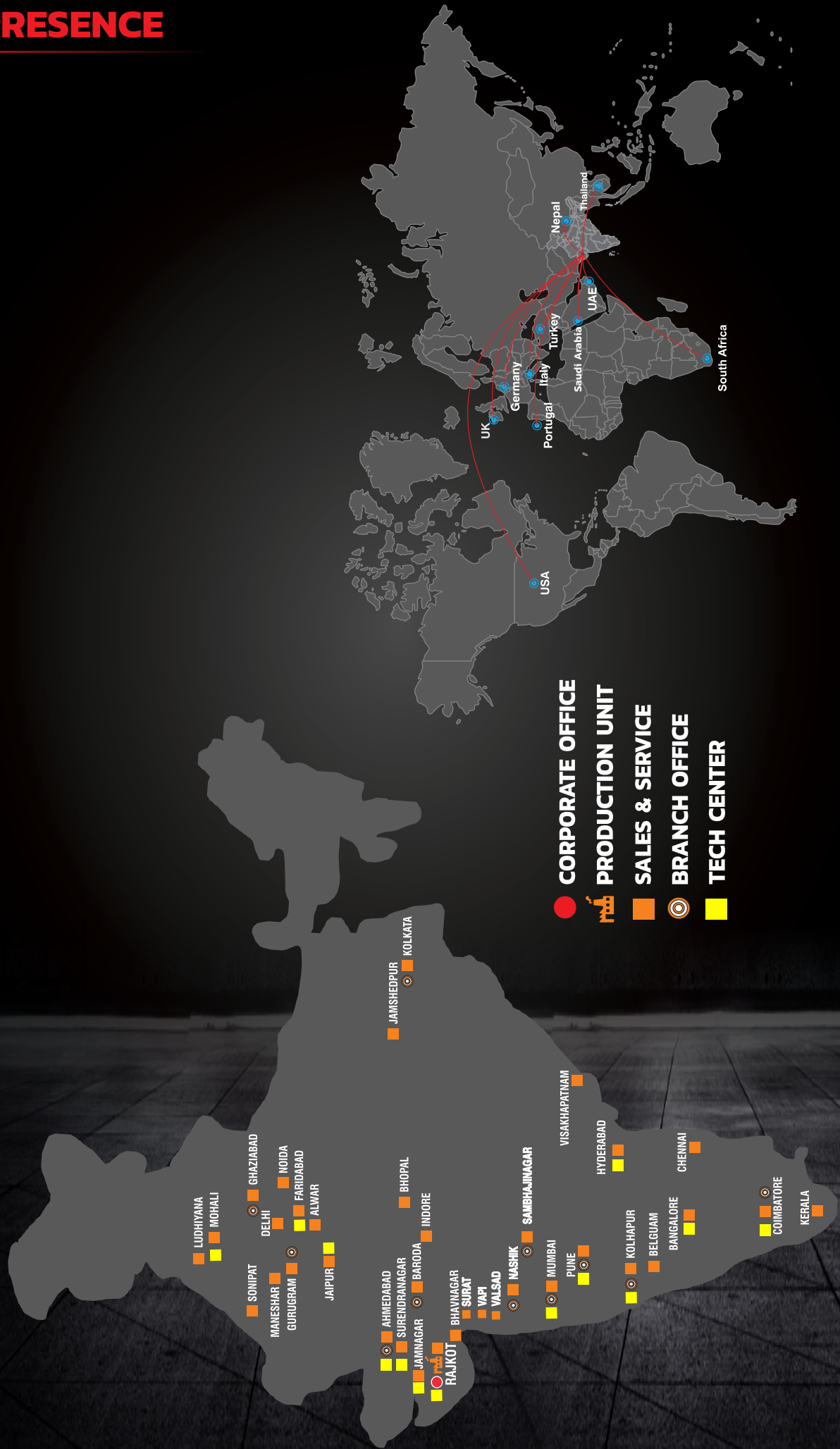
VIBRANT – SERIES MACHINE CONFIGURATIONS

DESCRIPTION	UNIT	VIBRANT 1066	VIBRANT 1166
CAPACITY			
X AXIS TRAVEL	MM	1020	1100
Y AXIS TRAVEL	MM	610	650
Z AXIS TRAVEL	MM	610	650
RAPID FEED RATES X/Y/Z AXIS	M/MIN	30/30/24	30/30/30
DISTANCE FROM TABLE TO SPINDLE FACE	MM	140-750	140-790
TABLE			
TABLE SIZE (CLAMPING AREA)	MM	600x1120	600X1300
NO./WIDTH/CD OF T-SLOTS	MM	5/18/100	5/18/100
MAX SAFE LOAD ON TABLE	KG	1200	1100
MAIN SPINDLE			
TAPER	-	BT 40 / BT 50	BT 40 / BT 50
SPEED	RPM	80-8000 / 60-6000	80-8000 / 60-6000
CUTTING FEED RATE	MM/MIN.	1-10000	1-10000
RATED POWER (FANUC)	KW	11 / 15	11 / 15
AUTO TOOL CHANGER			
TYPE	-	TWIN ARM	TWIN ARM
NO. OF TOOLS	-	24/20	24 / 20
TOOL SELECTION	-	RANDOM	RANDOM
MAX. TOOL DIA. (POCKET FULL/EMPTY)	MM	80/150, 125/200	80/150, 125/200
TOOL LENGTH	MM	300/400	300/400
TOOL WEIGHT	KG	7/20	7/20
ACCURACY (AS PER JIS)			
POSITIONING	MM	0.010	0.01
REPEATABILITY	MM	0.007	0.007
INSTALLATION DATA			
PNEUAMTIC SUPPLY	BAR	6	6
MACHINE WEIGHT (APPROX)	KG	-	7170 / 7860
TOTAL CONNECTED LOAD	KVA	25	25
POWER SUPPLY	-	"AC 440 V, 50HZ, 3PH."	"AC 440 V, 50HZ, 3 PH."
MACHINE DIMENSIONS (WXDXH) (APPROX)	MM	2883 x 3325 x 3310	2990 x 3480 x 3290 (BT 40) 2990 x 3480 x 3375 (BT 50)
SYSTEM			
FANUC	-	OI MF PLUS (ADV MILL)	OI MF PLUS (ADV MILL)
SIEMENS	-	828D	828D
MITSUBISHI	-	M80 V	M80 V

VIBRANT – SERIES MACHINE CONFIGURATIONS

DESCRIPTION	UNIT	VIBRANT 1366
CAPACITY		
X AXIS TRAVEL	MM	1310
Y AXIS TRAVEL	MM	650
Z AXIS TRAVEL	MM	650
RAPID FEED RATES X/Y/Z AXIS	M/MIN	30/30/30
DISTANCE FROM TABLE TO SPINDLE FACE	MM	140 – 790
TABLE		
TABLE SIZE (CLAMPING AREA)	MM	650X1450
NO./WIDTH/CD OF T-SLOTS	MM	5/18/100
MAX SAFE LOAD ON TABLE	KG	1300
MAIN SPINDLE		
TAPER	-	BT 40 / BT 50
SPEED	RPM	80-8000 / 60-6000
CUTTING FEED RATE	MM/MIN.	1-10000
RATED POWER (FANUC)	KW	11 / 15
AUTO TOOL CHANGER		
TYPE	-	TWIN ARM
NO. OF TOOLS	-	24 / 20
TOOL SELECTION	-	RANDOM
MAX. TOOL DIA. (POCKET FULL/EMPTY)	MM	80/150, 125/200
TOOL LENGTH	MM	300/400
TOOL WEIGHT	KG	7/20
ACCURACY (AS PER JIS)		
POSITIONING	MM	0.01
REPEATABILITY	MM	0.007
INSTALLATION DATA		
PNEUAMTIC SUPPLY	BAR	6
MACHINE WEIGHT (APPROX)	KG	7405 / 8095
TOTAL CONNECTED LOAD	KVA	26
POWER SUPPLY	-	"AC 415 V, 50HZ, 3 PH."
MACHINE DIMENSIONS (WXDXH) (APPROX)	MM	3590 x 3480 x 3320 (BT 40) 3590 x 3480 x 3405 (BT 50)
SYSTEM		
FANUC	-	O1 MF PLUS (ADV MILL)
SIEMENS	-	828D
MITSUBISHI	-	M80 V

OUR PRESENCE



FOR MORE INFORMATION PLEASE CONTACT

WEST ZONE

Rajkot : 93777 87930
Jamnagar : 74860 42366
Surendranagar : 74860 42366
Morbi : 93777 87930
Bhavnagar : 93777 87930
Ahmedabad : 93775 87930
Sanand : 93775 87930
Anand : 93775 87930
Baroda : 63560 02810
Halol : 63560 02810
Surat : 63560 02810
Vapi : 63560 02810
Mumbai (C) : 70964 55955
Mumbai (W) : 93203 87930
Nasik : 93713 87930
Aurangabad : 93456 87930
Kolhapur : 70690 11499
Pune : 93210 87930
Ahmednagar : 93210 87930

NORTH ZONE

Delhi : 76000 10288
Faridabad : 74860 29853
Ghaziabad : 70690 75161
Noida : 70690 75161
Gurugram : 72111 08487

Haryana : 89504 69265
Sonipat : 89504 69265
72111 02818

Ludhiana : 99886 93302
Mohali : 99886 93302

Jaipur : 72111 88869
Alwar : 72111 88869
Jodhpur : 72111 88869

EAST ZONE

Kolkata : 93758 45361
Jameshedpur : 93758 45361

SOUTH ZONE

Hyderabad : 70961 50505
Bangalore : 72111 03869
Chennai : 63560 02822

Belgaum : 91641 02610

Coimbatore : 72111 02822
Trichy : 72111 02822
Kerala : 72111 02822

CENTRAL ZONE

Indore : 99747 97756
Bhopal : 87706 96570

*at
your service
anytime
anywhere*



MACPOWER CNC MACHINES LTD.



Regd. office address : Plot No. 2234, Near Kranti Gate,
GIDC, Metoda - 360 021. Rajkot, Gujarat. (INDIA)

+91 2827 287930/31 sales@macpowercnc.com www.macpowercnc.com



Note : Technical Specifications and Colors are subject to change as a part of continuous development.