

TURN O' MILL



TURN O' MILL - 200

ONE NUMBER - MULTI SOLUTIONS

FOR SALES INQUIRIES & CUSTOMER CARE

7998-7998-16



TURN O' MILL 200 MACHINE CONFIGURATIONS

DESCRIPTION	UNIT	TURN O' MILL 200
CAPACITY		
Std. Turning Dia.	mm	200
Max. Turning Dia.	mm	250
Swing Over Bed	mm	450
Max. Turning Length	mm	500
Dist. Between Center	mm	600
SLIDES		
Cross (X axis) Travel	mm	225
Longitudinal (Z axis) Travel	mm	525
Rapid Feed (X & Z axis)	m/min	24
MAIN SPINDLE		
Spindle Motor (Continuous Rating)	kW	7.5
(15 min. Rating) (Fanuc)	kW	11
Spindle Bore	mm	63
Spindle Nose	—	A2 - 6
Max. Bar Capacity	mm	51
Chuck Size	mm	200
Speed Range	rpm	50 - 3000
Full Power Speed Range	rpm	1000 - 3000
TURRET		
No. of Station	—	12
No. of Driven Station	—	12
Max. Boring Bar Capacity	mm	32
Live Tool Holder	—	VDI 30
Max. Live Tool Speed	rpm	5000
Live Motor Power	kW	4.1
TAIL STOCK		
Quill Diameter	mm	80
Quill Stroke	mm	100
ACCURACY		
Positioning Accuracy	mm	0.008
Repeatability	mm	0.007
OTHER DATA		
Weight (Approx.)	kg	4000
Dimensions (W x D x H)(Approx.)	mm	2500 x 2050 x 2000
CONTROL SYSTEM		
Fanuc	—	Oi MF
Siemens	—	828 D
Mitsubishi	—	E 80

MACHINE DIMENSIONS

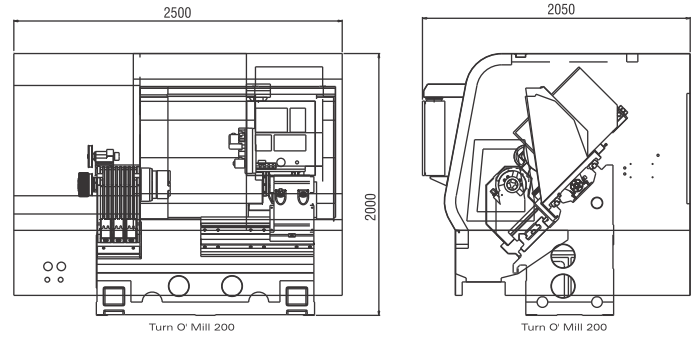

MACHINING RANGE

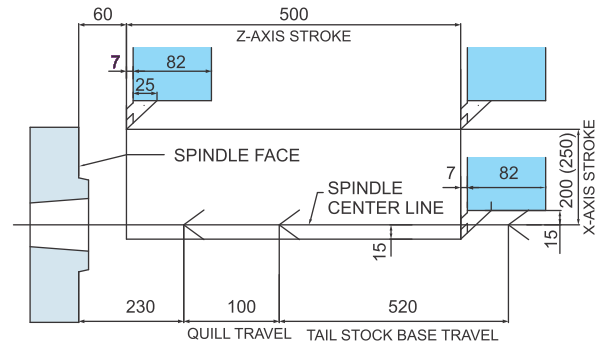

POWER DIAGRAM

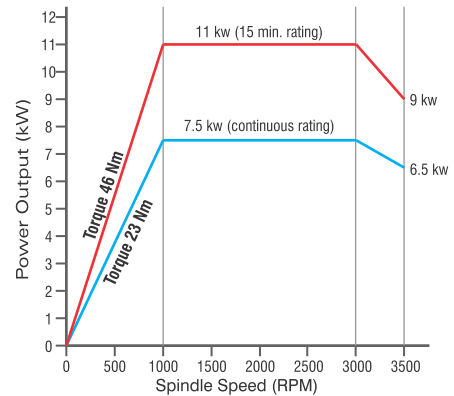

COMPONENTS



MACPOWER CNC MACHINES LIMITED

Regd. office address : Plot No. 2234, Near Kranti Gate,
GIDC, Metoda - 360 021. Rajkot, Gujarat. (INDIA)

+91 2827 287930 / 31

sales@macpowercnc.com

www.macpowercnc.com



FOR MORE INFORMATION PLEASE CONTACT

WEST ZONE

Rajkot	: 93777 87930
Jamnagar	: 74860 42366
Surendranagar	: 74860 42366
Morbi	: 93777 87930
Bhavnagar	: 93777 87930
Ahmedabad	: 93775 87930
Sanand	: 93775 87930
Anand	: 93775 87930
Baroda	: 63560 02810
Halol	: 63560 02810
Surat	: 93753 87930
Vapi	: 93753 87930
Mumbai	: 93203 87930
Nasik	: 93713 87930
Aurangabad	: 93456 87930
Kolhapur	: 72858 55955
Pune	: 93210 87930
Ahmednagar	: 93210 87930

NORTH ZONE

Delhi	: 76000 10288
Faridabad	: 74860 29853
Ghaziabad	: 72111 02820
Noida	: 76000 10288
Gurugram	: 63588 11123
Haryana	: 89504 69265
Sonipat	: 89504 69265
Ludhiana	: 99886 93302
Mohali	: 99886 93302
Jaipur	: 72111 88869
Alwar	: 72111 88869
Jodhpur	: 72111 88869

EAST ZONE

Kolkata	: 93758 45361
Jameshpur	: 93758 45361

SOUTH ZONE

Hyderabad	: 72111 03869
Bangalore	: 72111 03869
Chennai	: 63560 02822

Belgaum	: 91641 02610
---------	---------------

Coimbatore	: 72111 02822
Trichy	: 72111 02822
Kerala	: 72111 02822

CENTRAL ZONE

Indore	: 99747 97756
Bhopal	: 87706 96570

TURN O' MILL



TURN O' MILL - 300

ONE NUMBER - MULTI SOLUTIONS

FOR SALES INQUIRIES & CUSTOMER CARE

7998-7998-16



TURN O' MILL 300 MACHINE CONFIGURATIONS

DESCRIPTION	UNIT	TURN O' MILL 300
CAPACITY		
Std. Turning Dia.	mm	300
Max. Turning Dia.	mm	350
Swing Over Bed	mm	550
Max. Turning Length	mm	500
Dist. Between Center	mm	600
SLIDES		
Cross (X axis) Travel	mm	275
Longitudinal (Z axis) Travel	mm	525
Rapid Feed (X & Z axis)	m/min	24
MAIN SPINDLE		
Spindle Motor (Continuous Rating) (15 min. Rating) (Fanuc)	kW	11 / 15 "P" Series
Spindle Bore	mm	75
Spindle Nose	—	A2 - 8
Max. Bar Capacity	mm	60
Chuck Size	mm	300
Speed Range	rpm	50 - 2500
Full Power Speed Range	rpm	1000 - 1500
TURRET		
No. of Station	—	12
No. of Driven Station	—	12
Max. Boring Bar Capacity	mm	40
Live Tool Holder	—	VDI 40
Max. Live Tool Speed	rpm	5000
Live Motor Power	kW	4.1
TAIL STOCK		
Quill Diameter	mm	80
Quill Stroke	mm	100
ACCURACY		
Positioning Accuracy	mm	0.008
Repeatability	mm	0.007
OTHER DATA		
Weight (Approx.)	kg	4500
Dimensions (W x D x H)(Approx.)	mm	2500 x 2150 x 2100
CONTROL SYSTEM		
Fanuc	—	Oi TF
Siemens	—	828 D
Mitsubishi	—	E 80

MACHINE DIMENSIONS

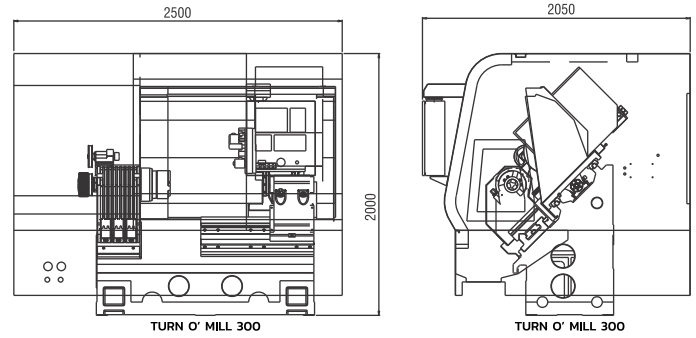

MACHINING RANGE

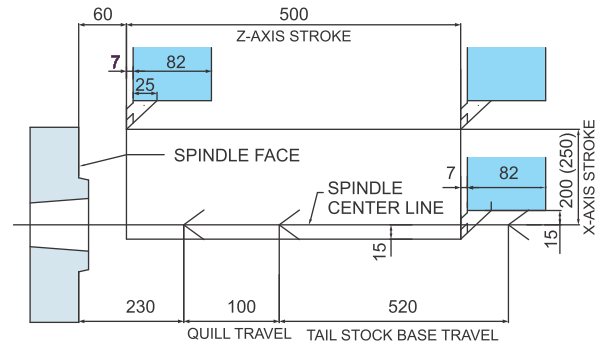

POWER DIAGRAM

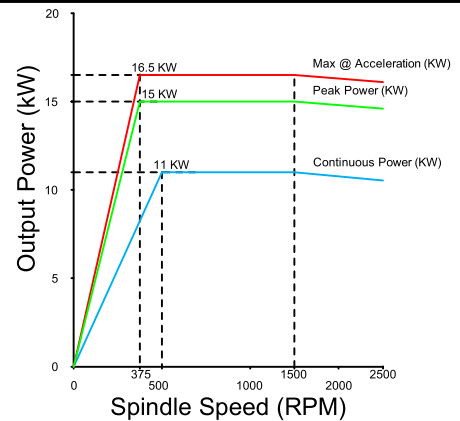

COMPONENTS



MACPOWER CNC MACHINES LIMITED

Regd. office address : Plot No. 2234, Near Kranti Gate,
GIDC, Metoda - 360 021. Rajkot, Gujarat. (INDIA)

+91 2827 287930 / 31

sales@macpowercnc.com

www.macpowercnc.com



FOR MORE INFORMATION PLEASE CONTACT

WEST ZONE

Rajkot	: 93777 87930
Jamnagar	: 74860 42366
Surendranagar	: 74860 42366
Morbi	: 93777 87930
Bhavnagar	: 93777 87930
Ahmedabad	: 93775 87930
Sanand	: 93775 87930
Anand	: 93775 87930
Baroda	: 63560 02810
Halol	: 63560 02810
Surat	: 93753 87930
Vapi	: 93753 87930
Mumbai	: 93203 87930
Nasik	: 93713 87930
Aurangabad	: 93456 87930
Kolhapur	: 72858 55955
Pune	: 93210 87930
Ahmednagar	: 93210 87930

NORTH ZONE

Delhi	: 76000 10288
Faridabad	: 74860 29853
Ghaziabad	: 72111 02820
Noida	: 76000 10288
Gurugram	: 63588 11123
Haryana	: 89504 69265
Sonipat	: 89504 69265
Ludhiana	: 99886 93302
Mohali	: 99886 93302
Jaipur	: 72111 88869
Alwar	: 72111 88869
Jodhpur	: 72111 88869

EAST ZONE

Kolkata	: 93758 45361
Jameshedpur	: 93758 45361

SOUTH ZONE

Hyderabad	: 72111 03869
Bangalore	: 72111 03869
Chennai	: 63560 02822

Belgaum	: 91641 02610
---------	---------------

Coimbatore	: 72111 02822
Trichy	: 72111 02822
Kerala	: 72111 02822

CENTRAL ZONE

Indore	: 99747 97756
Bhopal	: 87706 96570