

VERTICAL MACHINING CENTER



JUMBO SERIES

ONE NUMBER - MULTI SOLUTIONS

FOR SALES INQUIRIES & CUSTOMER CARE

7998-7998-16



www.macpowercnc.com



WHY MACPOWER ?

- Totally In-house Manufacturing Capability
- Wide range of products to choose from
- Effective "Cost to Performance" solution provider
- Believing in partnership with customers and not as buyer and seller
- Efficient after sales service back up
- Availability of spares
- Emphasis on continuous R & D & Training
- Flexibility & Openness to manufacture customized machines
- Fast decision making process
- Macpower is a company with a modern outlook – giving you contemporary solutions through time-tested expertise.

COMPANY PROFILE

Macpower CNC Machines Limited (Macpower) welcomes to the world of machining excellence. More than one and half decades of experience and the vision towards creating a niche has transformed Macpower into India's fastest growing CNC Manufacturing Company. This meteoric growth is a result of Macpower's vision of par excellence to manufacture state of the art products, adopting the best in technology.

In 2003, Macpower Group started Macpower CNC Machines Limited, CNC Machines manufacturing unit in an area of around 4 acres and has grown to almost double thereafter with 2 units in operation at present situated at Metoda G. I. D.C., Rajkot (India). Macpower is registered to ISO 9001(Design), a universally accepted quality assurance designation and MSE-1 certification for highest financial strength and operational ability by CRISIL.

The modern headquarters contains a spacious State of the Art Machine Shop, Totally Equipped Assembly Shops, All Modern Measuring and Testing Equipments, Technologically Advanced Sheet Metal Unit and One of it's Kind Powder Coating Plant make Macpower Totally In-House Manufacturing Company.

Macpower is currently offering widest range of 9 different product categories namely Turning Center, Twin Spindle Turning Center, VMC, Twin Spindle VMC, TurnMill Center, HMC, VTL, DTC, Grinder with 27 versions and 60+ different models serving 27 industry segment world wide with 8000+ installations.

Sales & Service Team presence in 37 cities across the country with 107 qualified engineers and 9 business associates; establishment of multiple regional offices and technology centers across the country to have better connect with our valued customers.



OUR VISION

To Provide Best Solution In Machine Tool Industry.

OUR MISSION

Fostering A Spirit Of Continuous Learning And Innovation.

To Offer World Class Products Through Continuous Innovation.

To Reach New Sectors Of Industry In Particular And Society At Large By Offering Products Which Make Change In Present State Of Machine Tools.

To Nurture Best Brains In The Company So As To Develop Them As A Future Leader To Enhance The Company To A Newer Level.

To Provide Quick And Effective Service Base To Enhance Customer Satisfaction Index.





MACHINE SHOP AREA



ASSEMBLY AREA



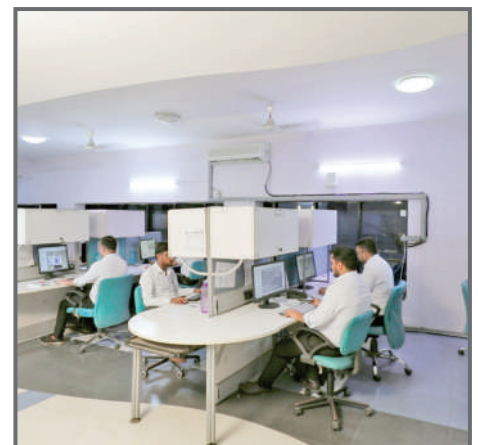
POWDER COATING AREA



SHEET METAL AREA



SPINDLE ASSEMBLY AREA



RESEARCH AND DEVELOPMENT

Major strength of our product quality is usage of highly precision parts as a part of our In-house manufacturing facilities. We have well qualified, trained skilled intellectual capital to manage manufacturing of High technology driven machines. We have proven state of the art manufacturing and assembly facilities to fulfill the customers' need.

We have **IN HOUSE FACILITIES LIKE,**

The Ultra-Modern **MACHINE SHOP** hosts an a series of mother machineries like multi axes internal and external thread grinder, moving column boring machine, multiple DCMs, tooled up HMCs, surface grinder, series of VMCs, Turn Mill Center along with latest material handling facilities and all the mother machineries are equipped with latest high end tooling and separate set of measuring instruments and QC procedure is being laid down for testing of machined components.

In House **SPINDLE MANUFACTURING AREA** equipped with Kellenberger KEL 100 Universal Cylindrical Grinder with internal and external Thread Grinding Facility and Spindle assembly along with Controlled Temperature Precision Room with Hi tech Spindle Balancing System.

ASSEMBLY SHOP has been established with Ucreate flooring, Hi-tech Assembly equipment's & Totally dust Free Environment. In addition Assembly set up classified with product categories like **TURNING CENTERS, MACHINING CENTERS, TURN MILLS CENTER & MULTI AXES CENTERS.**

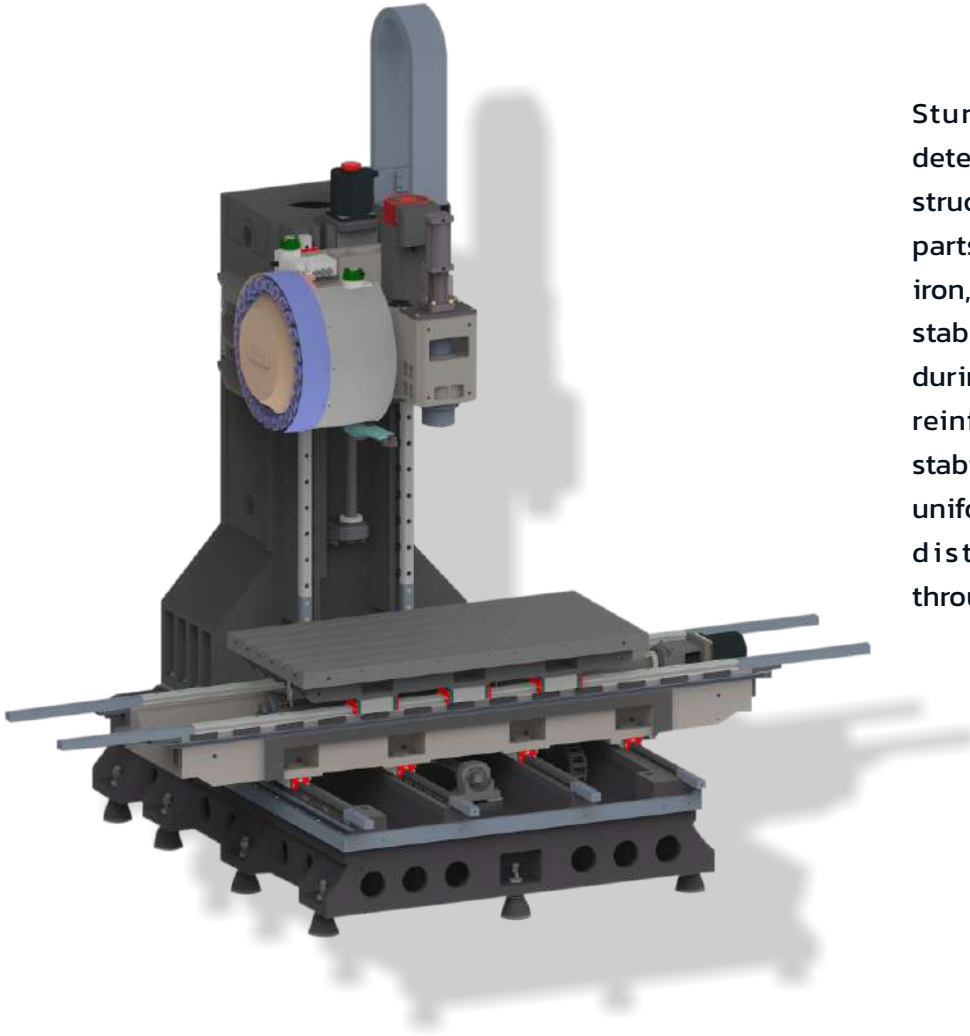
SHEET METAL division is equipped with 8 Axes AMADA Press Brake with Auto Angle correction, SLTL fiber laser profile cutting machine, Modular welding with Assembly set up & Separate Storage Area for ready to use Sheet Metal enclosures for the world class machine with high quality sheet required for the machine guarding.

POWDER COATING PLANT is performing with 11 Tank PT Hot and Cold Process with GEMA Automatic Powder Coating Gun system for preventing from corrosion and giving the best aesthetically appeal design with dynamic looks of machines.

At Macpower **R&D department**, we have intelligent minds with diverse backgrounds to develop technology that is not just effective today, but also tomorrow.

As our machine development process afforded by the incorporation of digital design techniques, we were able to take an idea and turn it into a prototype in just under one to two months.

RIGID STRUCTURE



Sturdiness of the foundation determined the soundness of the structure. The major construction parts are based on FG260 grade cast iron, to ensure optimum harmonic stability and maximum damping during cutting. Base and column are reinforced with heavy ribs for stability and least distortion. The uniform dense, fine graded casting distributed stress and heat throughout the machine structure.

HIGH CAPACITY ACCURATE SPINDLE



The precision cartridge spindle unit having three super precise angular contact bearings at front and two at rear end, this combination ensures higher stiffness. Bearings are perfectly aligned and grease packed for long life.

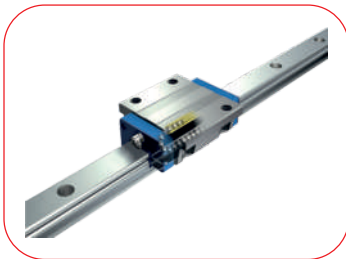
Spindle is indirectly driven by high speed AC spindle motor with reduced pulley ratio, to achieve high spindle torque and optimal performance of machine.

DOUBLE-ANCHORED BALL SCREWS



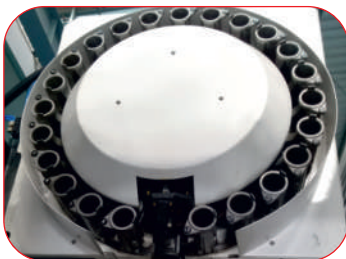
Ball Screws are directed by direct coupled AC servo motor with flexible coupling. This greatly improves positioning accuracy, and provides more accurate threading and contouring. Ball Screws are anchored at both ends and inspected for parallelism with axis guide. Pre-loaded ball nuts eliminate backlash.

PRECISE LINER GUIDEWAYS



All axes are furnished with precise and heavy load capacity re-circulating ball guide ways enabling high acceleration-de acceleration and hence better productivity

RELIABLE ATC



Twin arm type side mounted ATC driven by screw and cam speed up tool changing time with random access and resulted in reduce cycle time and higher productivity. Each subsystem is tested for innumerable cycle at every stage to enhance reliability.

ADVANCE INSPECTION TECHNOLOGY



Laser Calibration is carried out to insure the linear accuracy, providing accurate compensation for pitch and backlash. The machine facilities the attainment of positional accuracy up to 0.01 mm / 300 mm and repeatability accuracy up to 0.007 mm.

PRODUCTIVITY ENHANCEMENT OPTIONS

4TH & 5TH AXIS CAPABILITY



For maximum application and cutting flexibility, usage of 4th Axis or 5th Axis rotary table with high resolution feedback system can be opted. These rotary tables can be programmed through the control system, that can be used to increase productivity by multiple side workpiece in single setting

COOLANT THROUGH SPINDLE (CTS)



This option provides high pressure filtered coolant directly to the cutting edge minimizing heat distractions, ensuring maximum productivity with today's high performance tooling. High recommended for jobs demanding deep boring and tapping.

GEAR BOX



For application requiring high cutting for harder material or high cutting speed for soft materials, 2-speed gearbox need to be opted. These gearbox provide higher cutting torque at lower RPM with auto shifting mechanism keeping power constant. Such gearbox get directly coupled to main spindle motor giving production flexibility without disturbing precision.

FLUSH COOLANT SYSTEM

Efficient chip remove is one of the important factor for better productivity with un-interrupted machining operations can be efficiently enhanced by selections of flush coolant system, high pressure coolant splash via flexible nozzles can be targeted to area of maximum chip accumulation. such a system enhance reduction in machining down time to operate and hence positively effecting productivity.

CHIP CONVEYOR



Machine can be mounted with chip conveyor option for efficient Swarf removal for entire series. such type of arrangements is very much useful for applications requiring continues machining hours having much metal removal. with help of downtime can be reduce drastically.

PROBES



A wide choice of spindle and surface-sensing probes as tool & job probes with infrared / radio laser transmission technology are available for increased spindle utilization, work piece setup and work piece measurement.

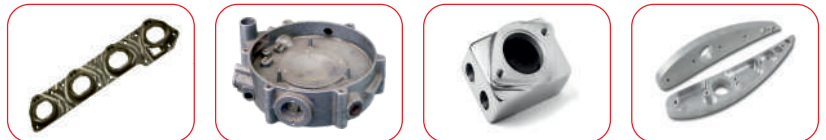
V 1377 SUPER

VERTICAL MACHINING CENTER

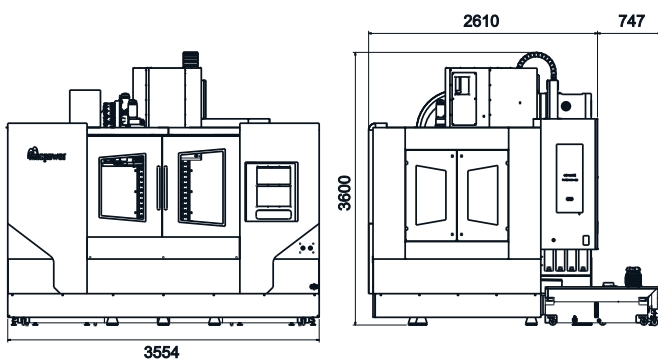


TABLE SIZE (CLAMPING AREA)	MM	1450 x 700
AXIS STROKE (X / Y / Z)	MM	1310 / 710 / 710
RAPID FEED RATES X/Y/Z AXIS	M/MIN	24/24/20
LOAD CAPACITY	KG	1500
SPINDLE	-	BT40/BT50
RATED POWER(FANUC)	KW	11/15
WEIGHT (APPROX)	KG	9525/10120
DIMENSIONS (APPROX) (WXDXH)	MM	3554x3357x3600 (BT-40) 3554x3357x3685 (BT-50)

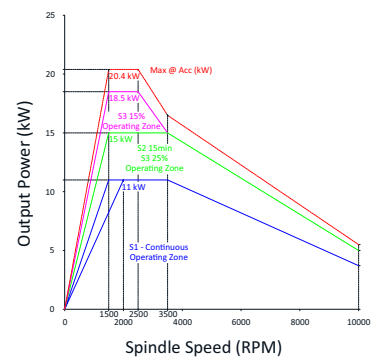
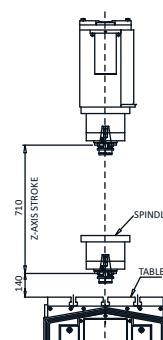
COMPONENTS



Machine Dimensions



MACHINING RANGE & POWER DIAGRAM



V 1588 SUPER

VERTICAL MACHINING CENTER

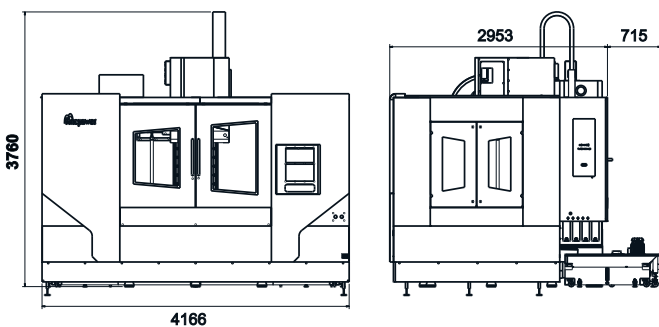


TABLE SIZE (CLAMPING AREA)	MM	800 x 1700
AXIS STROKE (X / Y / Z)	MM	1510 / 810 / 810
RAPID FEED RATES X/Y/Z AXIS	M/MIN	20/20/20
LOAD CAPACITY	KG	2200
SPINDLE	-	BT40/BT50
RATED POWER(FANUC)	KW	11/15
WEIGHT (APPROX)	KG	12280/(12930)
DIMENSIONS (APPROX) (WDXH)	MM	4166x3668x3760 (BT-40) 4166x3668x3845 (BT-50)

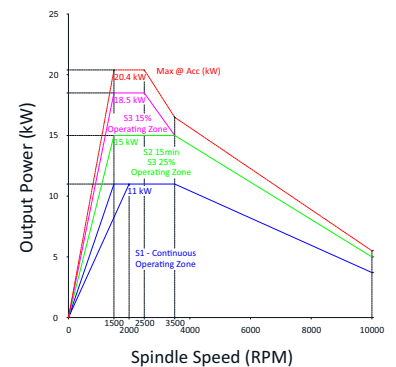
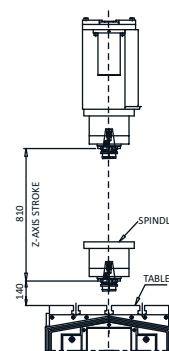
COMPONENTS



Machine Dimensions



MACHINING RANGE & POWER DIAGRAM



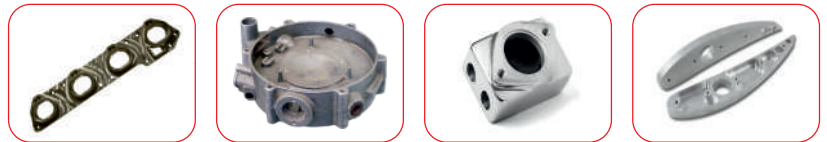
V 1688 SUPER

VERTICAL MACHINING CENTER

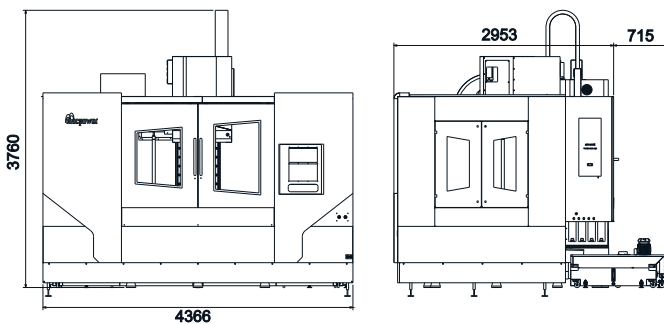


TABLE SIZE (CLAMPING AREA)	MM	800 x 1800
AXIS STROKE (X / Y / Z)	MM	1610 / 810 / 810
RAPID FEED RATES X/Y/Z AXIS	M/MIN	20/20/16
LOAD CAPACITY	KG	2300
SPINDLE	-	BT40/BT50
RATED POWER(FANUC)	KW	11/15
WEIGHT (APPROX)	KG	12500/13150
DIMENSIONS (APPROX) (WXDXH)	MM	4366x3668x3760 (BT-40) 4366x3668x3845 (BT-50)

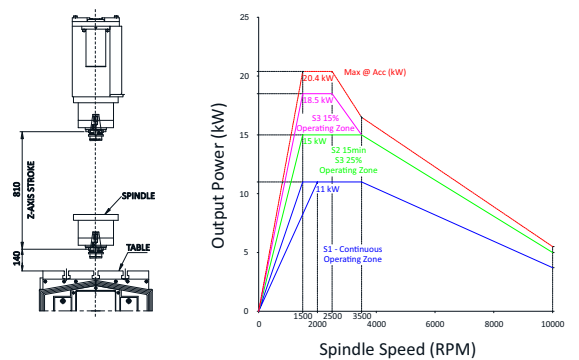
COMPONENTS



Machine Dimensions



MACHINING RANGE & POWER DIAGRAM



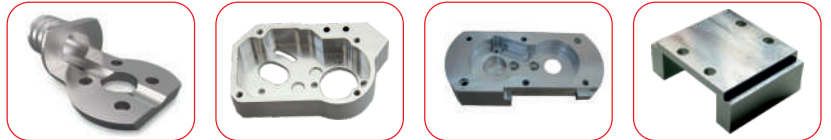
V 1888 SUPER

VERTICAL MACHINING CENTER

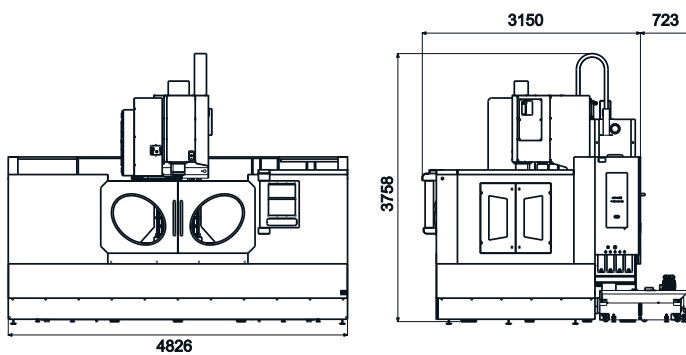


TABLE SIZE (CLAMPING AREA)	MM	800 x 2000
AXIS STROKE (X / Y / Z)	MM	1825 / 810 / 810
RAPID FEED RATES X/Y/Z AXIS	M/MIN	20/20/16
LOAD CAPACITY	KG	2600
SPINDLE	-	BT40/BT50
RATED POWER(FANUC)	KW	11/15
WEIGHT (APPROX)	KG	13500/14150
DIMENSIONS (APPROX) (WDXH)	MM	4826x3873x3758 (BT-40) 4826x3873x3843 (BT-50)

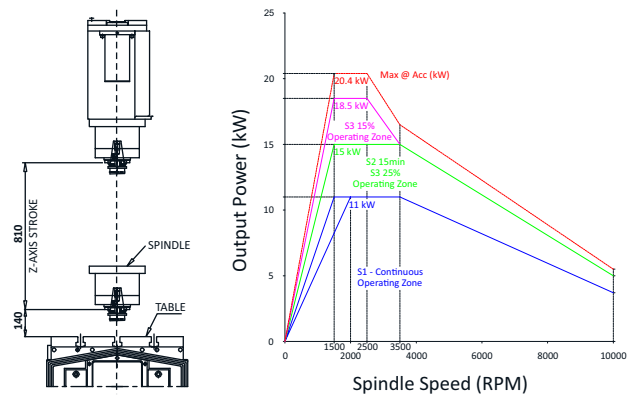
COMPONENTS



Machine Dimensions



MACHINING RANGE & POWER DIAGRAM



V 2199 SUPER

VERTICAL MACHINING CENTER

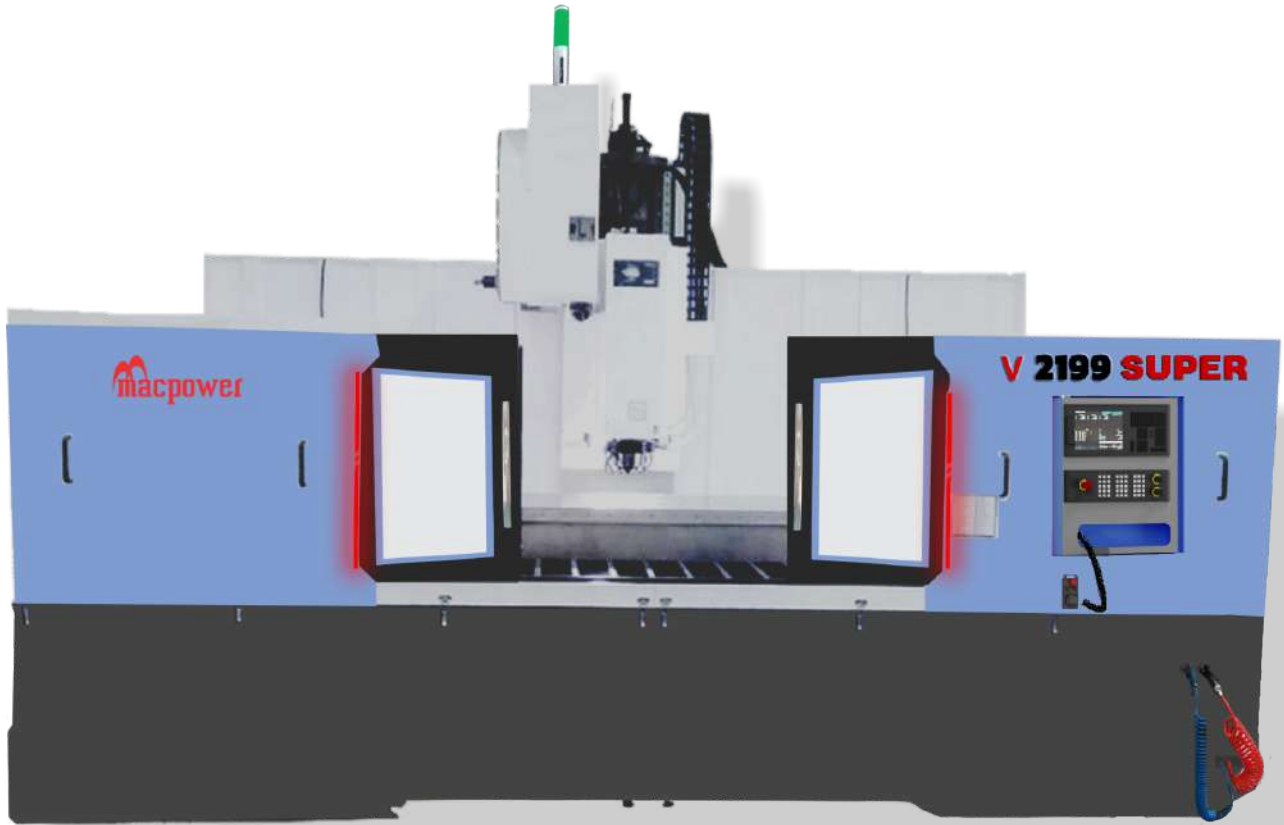
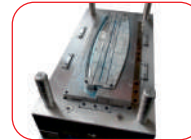
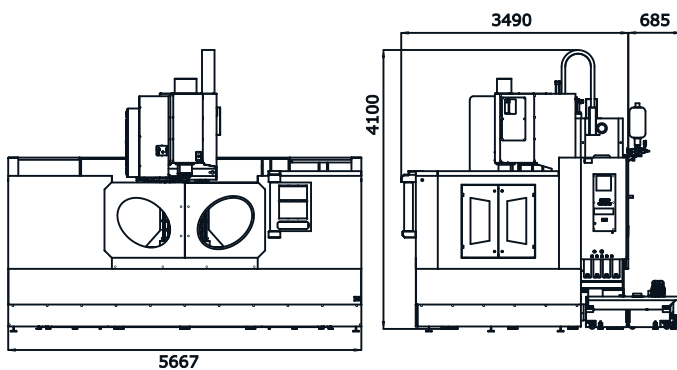


TABLE SIZE (CLAMPING AREA)	MM	900 x 2400
AXIS STROKE (X / Y / Z)	MM	2100 / 910 / 910
RAPID FEED RATES X/Y/Z AXIS	M/MIN	15/15/15
LOAD CAPACITY	KG	2800
SPINDLE	-	BT40/BT50
RATED POWER(FANUC)	KW	11/15
WEIGHT (APPROX)	KG	18000/18800
DIMENSIONS (APPROX) (WDXH)	MM	5667x4190x4100 (BT-40) 5667x4190x4185 (BT-50)

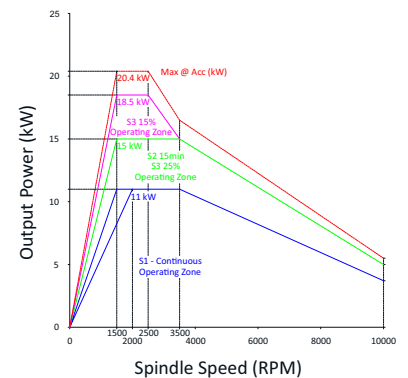
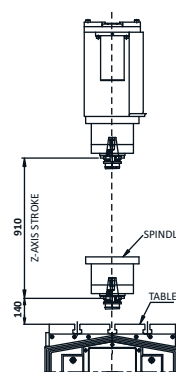
COMPONENTS



Machine Dimensions



MACHINING RANGE & POWER DIAGRAM



JUMBO SERIES MACHINE CONFIGURATIONS

DESCRIPTION	UNIT	V 1377 SUPER	V 1588 SUPER
CAPACITY			
X AXIS TRAVEL	MM	1310	1510
Y AXIS TRAVEL	MM	710	810
Z AXIS TRAVEL	MM	710	810
RAPID FEED RATES X/Y/Z AXIS	M/MIN	24/24/20	20/20/20
DISTANCE FROM TABLE			
TOP TO SPINDLE FACE	MM	140-850	140-950
TABLE			
TABLE SIZE (CLAMPING AREA)	MM	700 X 1450	800 X 1700
NO./WIDTH/CD OF T-SLOTS	MM	5/18/125	6/18/125
MAX SAFE LOAD ON TABLE	KG	1500	2200
MAIN SPINDLE			
TAPER	-	BT40/BT50	BT40/BT50
SPEED	RPM	80-8000/60-6000	80-8000/60-6000
CUTTING FEED RATE	MM/MIN.	1-10000	1-10000
RATED POWER (FANUC)	KW	11/15	11/15
AUTO TOOL CHANGER			
TYPE	-	TWIN ARM	TWIN ARM
NO. OF TOOLS (BT 40/BT 50)	-	24/20	24/20
TOOL SELECTION	-	RANDOM	RANDOM
MAX. TOOL DIA. (POCKET FULL/EMPTY) (BT 40/BT 50)	MM	80/150, 125/200	80/150, 125/200
TOOL LENGTH (BT 40/BT 50)	MM	300/400	300/400
TOOL WEIGHT (BT 40/BT 50)	KG	7/20	7/20
ACCURACY (AS PER JIS)			
POSITIONING	MM	0.01	0.01
REPEATABILITY	MM	0.007	0.007
INSTALLATION DATA			
PNEUMATIC SUPPLY	BAR	6	6
MACHINE WEIGHT (APPROX)	KG	9525/10120	12280/(12930)
TOTAL CONNECTED LOAD	KVA	26	26
POWER SUPPLY	-	AC 440 V, 50HZ, 3PH.	AC 440 V ,50HZ, 3PH.
MACHINE DIMENSIONS			
(WXDXH) (APPROX)	MM	3554x3357x3600 (BT-40), 3554x3357x3685 (BT-50)	4166x3668x3760 (BT-40), 4166x3668x3845 (BT-50)
SYSTEM			
FANUC	-	OI MF PLUS	OI MF PLUS
SIEMENS	-	828D	828D
MITSUBISHI	-	M80 V	M80 V

ACCESSORIES

V 1688 SUPER

1610
810
810
20/20/16

140-950

800 X 1800
6/18/125
2300

BT40/BT50
80-8000/60-6000
1-10000
11/15

TWIN ARM
24/20
RANDOM
80/150, 125/200

300/400
7/20

0.01
0.007

6
12500 / 13150
26
AC 440 V ,50HZ, 3PH.

4366x3668x3760 (BT-40),
4366x3668x3845 (BT-50)

OI MF PLUS
828D
M80 V

V 1888 SUPER

1825
810
810
20/20/16

140-950

800 X 2000
6/18/125
2600

BT40/BT50
80-8000/60-6000
1-10000
11/15

TWIN ARM
24/20
RANDOM
80/150, 125/200

300/400
7/20

0.01
0.007

6
13500/14150
30
AC 440 V, 50HZ, 3 PH.

4826x3873x3758 (BT-40),
4826x3873x3843 (BT-50)

OI MF PLUS
828D
M80 V

V 2199 SUPER

2100
910
910
15/15/15

140-1050

900 X 2400
6/18/125
2800

BT40/BT50
80-8000/60-6000
1-10000
11/15

TWIN ARM
24/20
RANDOM
80/150, 125/200

300/400
7/20

0.01
0.007

6
18000/18800
30
AC 440 V ,50HZ, 3 PH.

5667x4190x4100 (BT-40),
5667x4190x4185 (BT-50)

OI MF PLUS
828D
M80 V

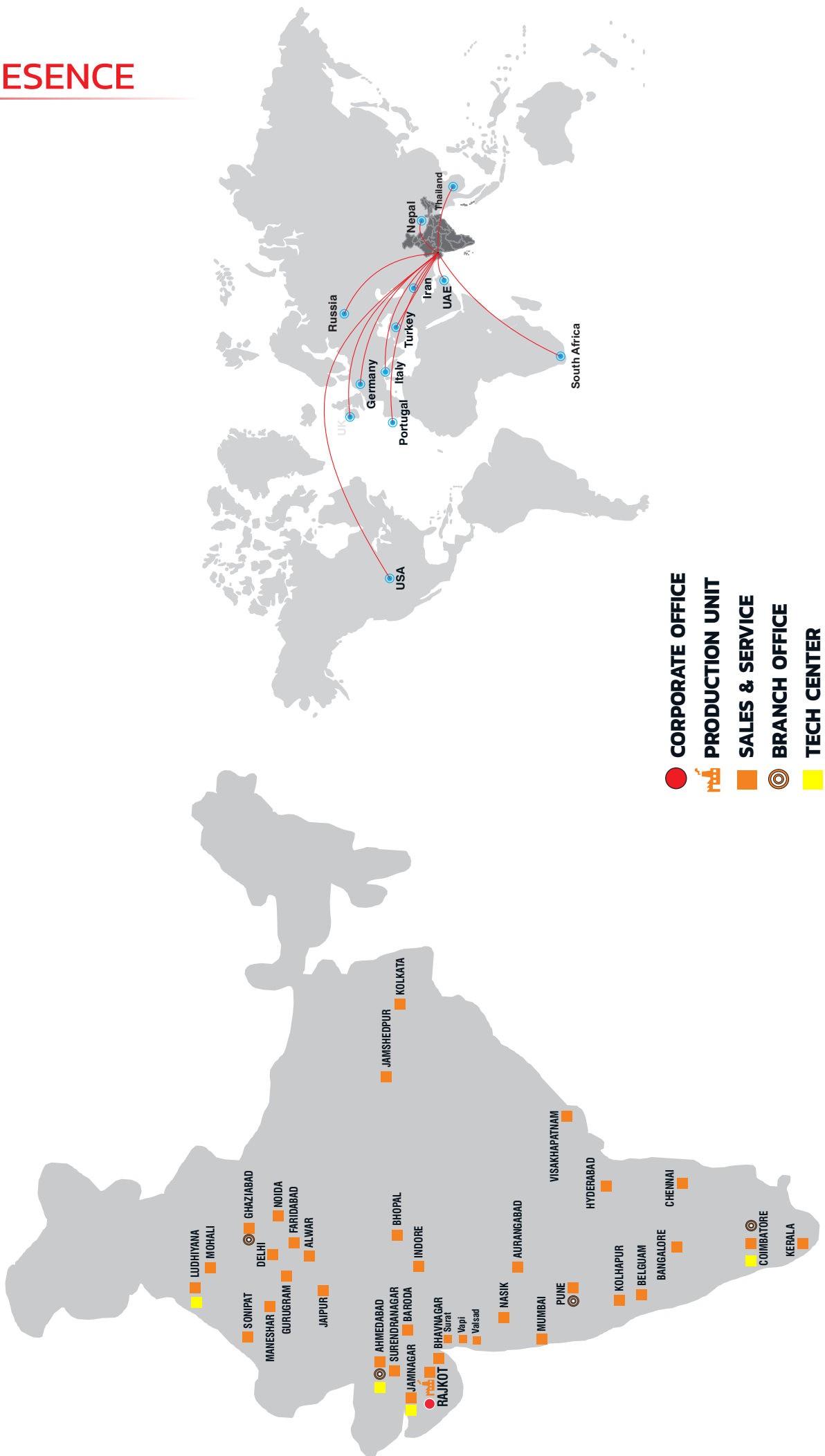
STANDARD

- LM GUIDEWAYS
- 24 TOOL ATC
- WORK LIGHT
- HAND WHEEL
- LEVELING PAD
- RING COOLANT
- PATROL LIGHT
- AIR GUN
- CENTRALIZED LUBRICATION SYSTEM
- PULL STUD
- DRY AIR CUTTING

OPTIONAL

- COOLANT GUN
- AUTO DOOR
- CHIP CONVEYOR
- LINEAR SCALE
- STABILIZER
- FLUSH COOLANT
- COOLANT THROUGH SPINDLE
- 30 TOOL ATC
- ROTARY TABLE
- ROTARY TILTING TABLE
- GEAR BOX
- HIGHER RPM SPINDLES
- SPINDLE CHILLER
- INDEXER
- TOOL PROBE
- WORK PROBE
- TOOLED UP SOLUTIONS
- VERTICAL AXIS PULL UP DURING POWER FAILURE

OUR PRESENCE



FOR MORE INFORMATION PLEASE CONTACT

WEST ZONE

Rajkot	:	93777 87930
Jamnagar	:	74860 42366
Surendranagar	:	74860 42366
Morbi	:	93777 87930
Bhavnagar	:	93777 87930
Ahmedabad	:	93775 87930
Sanand	:	93775 87930
Anand	:	93775 87930
Baroda	:	63560 02810
Halol	:	63560 02810
Surat	:	93753 87930
Vapi	:	93753 87930
Mumbai	:	93203 87930
Nasik	:	93713 87930
Aurangabad	:	93456 87930
Kolhapur	:	72858 55955
Pune	:	93210 87930
Ahmednagar	:	93210 87930

NORTH ZONE

Delhi	:	76000 10288
Faridabad	:	74860 29853
Ghaziabad	:	72111 02820
Noida	:	76000 10288
Gurugram	:	63588 811123
Haryana	:	89504 69265
Sonipat	:	89504 69265
Ludhiana	:	99886 93302
Mohali	:	99886 93302
Jaipur	:	72111 88869
Alwar	:	72111 88869
Jodhpur	:	72111 88869

EAST ZONE

Kolkata	:	93758 45361
Jameshedpur	:	93758 45361

SOUTH ZONE

Hyderabad	:	72111 03869
Bangalore	:	72111 03869
Chennai	:	63560 02822
Belgaum	:	91641 02610
Coimbatore	:	72111 02822
Trichy	:	72111 02822
Kerala	:	72111 02822

CENTRAL ZONE

Indore	:	99747 97756
Bhopal	:	87706 96570

at
your service
anytime
anywhere




macpower

MACPOWER CNC MACHINES LTD.

Regd. office address : Plot No. 2234, Near Kranti Gate,
GIDC, Metoda - 360 021. Rajkot, Gujarat. (INDIA)



+91 2827 287930/31



sales@macpowercnc.com



www.macpowercnc.com



Note : Technical Specifications and Colors are subject to change as a part of continuous development.